

# Manual

# Industrial air curtain

Model IndAC2

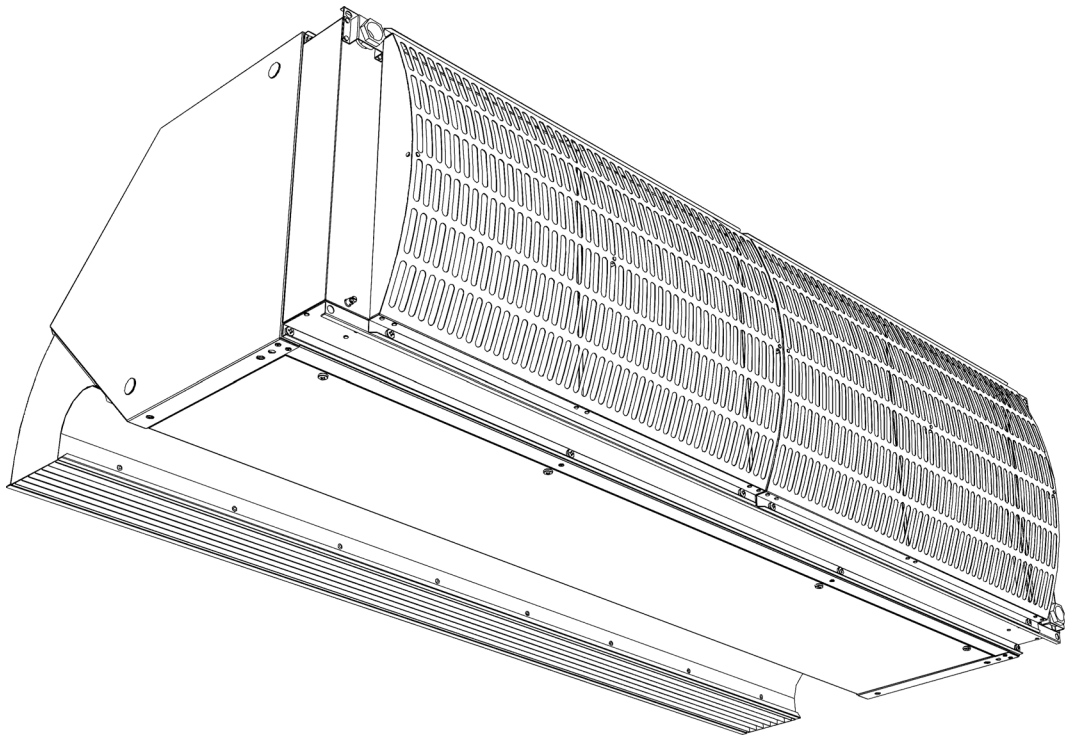

Version 6.0  
Original Manual

English



**biddle**

# . . . Contents

<b>I</b>	<b>Introduction</b>	<b>4</b>
	1.1 About this manual	4
	1.2 How to read this manual	4
	1.3 About the unit	5
	1.4 Components and accessories	14
	1.5 Safety instructions	15
<b>2</b>	<b>Installation</b>	<b>17</b>
	2.1 Inspection on delivery	17
	2.2 General working method	17
	2.3 Suspending the unit horizontally	18
	2.4 Installing the unit vertically	22
	2.5 Connecting the unit to the central heating system	25
	2.6 Connecting the unit to the mains supply	29
	2.7 Installing the <i>b-control</i> continuously variable controller	35
	2.8 Installing the <i>b-touch</i> control panel	40
	2.9 Installing external controls	44
	2.10 Finishing the unit	52
	2.11 Switching ON and checking operation	53
<b>3</b>	<b>Operation with <i>b-control</i></b>	<b>57</b>
	3.1 Introduction	57
	3.2 Switching ON and OFF	57
	3.3 Regulating the strength	57
<b>4</b>	<b>Operation with <i>b-touch</i></b>	<b>58</b>
	4.1 Introduction	58
	4.2 The Home screen	59
	4.3 Main menu	62
	4.4 Preferences	64
	4.5 Settings	65
	4.6 Configuration	66
	4.7 Maintenance	74
	4.8 USB	76
<b>5</b>	<b>Errors</b>	<b>78</b>
	5.1 Resolving simple problems	78
	5.2 Error messages on the control panel	81
	5.3 Remediating errors that are accompanied by an error message	82
	5.4 Remediating errors that are not accompanied by an error message	85

<b>6</b>	<b>Maintenance</b>	<b>87</b>
	6.1 Introduction	87
	6.2 Cleaning the unit	87
	6.3 Scheduled maintenance	87
<b>7</b>	<b>Servicing</b>	<b>89</b>
	7.1 Removing the fans	90
	7.2 Accessing the heating element	92
	7.3 Electronics module	93
	7.4 Removing the control circuit board	93
	7.5 Connecting the control circuit board	94
	7.6 Fuses	94
	7.7 LEDs	95
	7.8 Setting the unit code	95
	7.9 Resetting the PIN code	96
	7.10 Copying the settings	96
	7.11 Updating the software	98
	7.12 Composition of the Biddle control cable	99
<b>8</b>	<b>Dismantling</b>	<b>100</b>
<b>9</b>	<b>Addresses</b>	<b>101</b>
	<b>Keywords</b>	<b>102</b>

# I . . Introduction

## I.1 About this manual

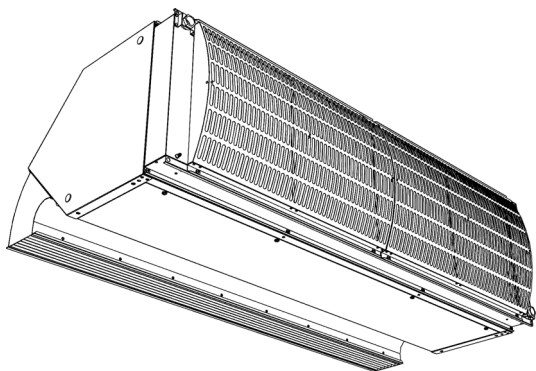

This manual describes the installation, operation and maintenance of the industrial air curtain model IndAC<sub>2</sub>. The manual also provides instructions and information for servicing activities.

## I.2 How to read this manual

### I.2.1 Designations used in the manual

The following symbols are used in the manual:



**Note:**

Refers to an important section in the text.



**Caution:**

If you do not carry out the procedure or action correctly, you may cause damage to the unit.

Follow the instructions precisely.



**Warning:**

**If you do not carry out the procedure or action correctly, you may cause physical injury and/or damage.**

Follow the instructions precisely.

**Danger:**

Is used to designate actions that are not permitted.

Ignoring this prohibition may lead to serious damage or to accidents resulting in physical injury.

### 1.2.2 Symbols used on the unit and in the manual

The following symbols indicate possible risks or hazards. The same symbols will also be found on the unit.

SYMBOL	DESCRIPTION
	<p><b>You have accessed a section of the unit containing components which carry a voltage.</b></p> <p>Access restricted to qualified maintenance staff only.</p> <p>Caution is required.</p>
	<p><b>This surface or component may be hot. Risk of burns on contact.</b></p>

### 1.2.3 Related documentation

In addition to this manual, the following documentation is also supplied with the unit:

- wiring diagram for installation and servicing.

## 1.3 About the unit

### 1.3.1 Applications

The air curtain model IndAC<sub>2</sub> is intended for the separation of climates between indoors and outdoors, or between two rooms. It is installed above or next to the door, across the full width or length of the doorway. The IndAC<sub>2</sub> model is primarily suitable for larger doors in industrial buildings.

Models having a maximum range (type MX) are intended for professional use.

Depending on the type, the air curtain is hung horizontally above the doorway, or erected vertically next to the doorway (on left or right, or on both sides).

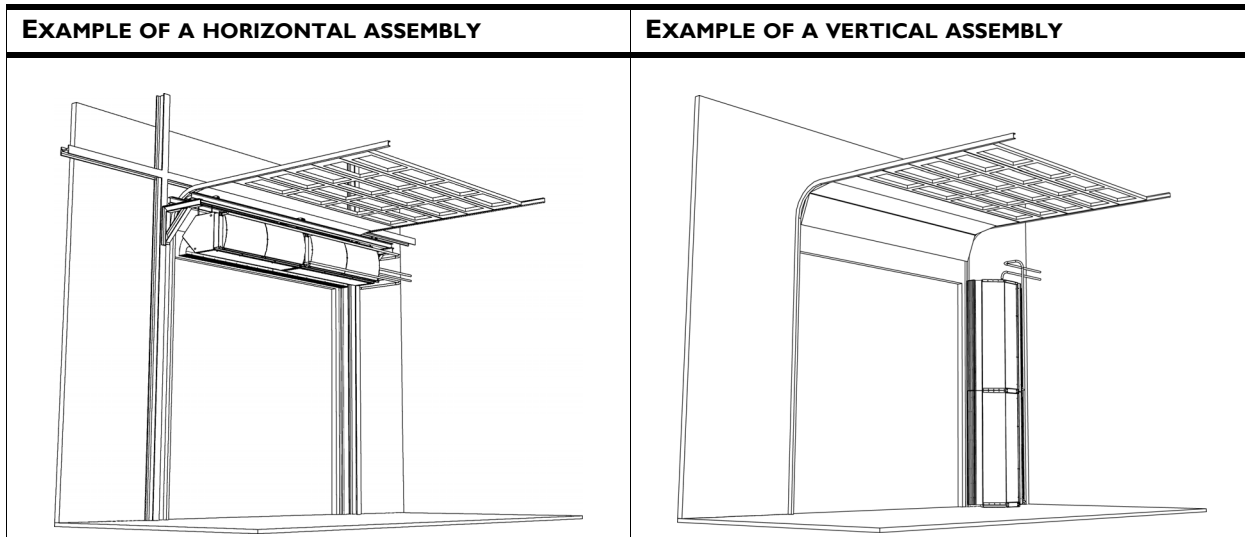

#### Other versions and intended use

Upon request, we can supply versions for non-standard applications.



#### **Warning:**

**Applications other than those described above are deemed to be usage other than for the intended purpose. Biddle is not liable for damage or loss resulting from usage other than for the intended purpose. Usage for the intended purpose also entails observance of the instructions in this manual.**

### 1.3.2 Operation

#### General

An air curtain above the door opening counteracts losses of energy and comfort. Located at the opening, it blows out a stream of air and thereby brings about the following:

- The exchange of air between two rooms due to a temperature difference (convection) is counteracted.
- The air that enters at floor level due to draught is possibly heated.

# CHIPS

## The automatic *CHIPS* control

Depending on the implementation, the unit may be equipped with an automatic *CHIPS* control.

The *CHIPS* control automatically adjusts the strength and heat of the unit to changing weather conditions. Thus, in all situations the energy loss is minimal and the comfort maximal.

*CHIPS* stands for “*Corrective Heat and Impulse Prediction System*”.

## Control when unit ‘on’

The unit and the automatic control were developed for situations in which the door stands open.

For the most efficient climate separation and preservation of comfort it is important that the airflow just touches the floor and is heated sufficiently. The unit continuously measures the values that are needed in order to achieve this:

1. The installation height (entered in the control panel)
2. The temperature difference between the two rooms:
  - outdoor temperature
  - room temperature
3. The temperature of the discharged air

As soon as the situation changes, the control adjusts the outlet flow rate and the temperature of the airflow to that.

## Control with unit ‘off’

If the unit is off – at night, for example – it is not active as climate separation.

If it is off, the unit can indeed still perform other functions:

- The unit can be set to keep the room at a minimal ‘night’ temperature.
- Water-heated models are equipped with integrated frost protection.

## Door response

The unit and the automatic control have been developed for situations in which the door stands open.

If the door is not continuously open, the operation can be adjusted to this:

- Normal operation: the unit is always discharging air.
- Direct door response: the unit responds directly to the opening and closing of the door.
- Gradual door response: the unit responds to the opening and closing of the door. The speed of response is based on the open/closed ratio.

**Note:**

If the door is closed, the unit works as a room temperature controller.

**Note:**

In some situations the unit does not discharge any air, even though it is on.

### 1.3.3 Type designation

The table below provides an overview of the available models of the industrial air curtain and the corresponding type designations. In combination, the type designations constitute the type code, for instance: IndAC<sub>2</sub> MX-150-H2-0-Auto.

If some part of the manual applies to certain models only, these will be indicated with the corresponding type designation, for example:

- 150: models with discharge width 150
- H: water-heated models
- E: electrically-heated models
- 0: horizontal models
- Auto: models with automatic control

**Note:**

In the illustrations in this manual, one type of unit is used as a general example. The outer appearance of your unit may be different but its function is the same, unless stated otherwise.



### Explanation of the type code

TYPE CODE ELEMENT	DESIGNATION	MEANING
product series	IndAC <sub>2</sub>	general designation for the series
capacity	ST	default range (door height 3-6 m)
	MX	maximum range (door height 5-8 m)
length	150, 200, 225 or 250.	discharge length in cm
battery type	H1 H2	water heating
	E	electrical heating
	A	without heating
installation position	0, 1L, 1R, 2L, 2R	In section 1.3.4 - Installation positions, pagina 9, the various installation positions are explained.
control	Basic	basic control
	Auto	automatic CHIPS control

#### See also:

1.3.4 "Installation positions" on page 9

### 1.3.4 Installation positions



The IndAC<sub>2</sub> air curtain is suitable for mounting in various installation positions. Depending on the situation, the unit can be placed above or next to the door. In total, there are five installation positions: 0, 1L, 1R, 2L, 2R.

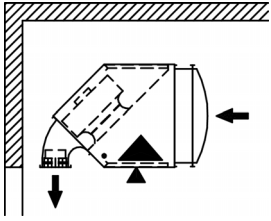
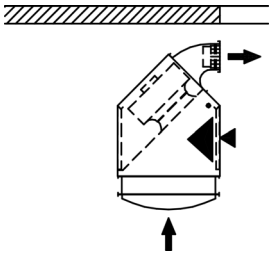
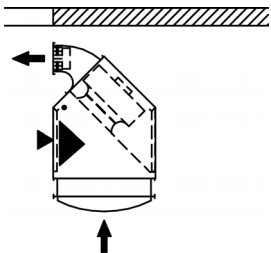
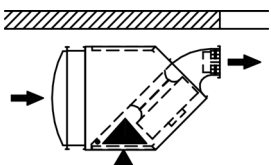
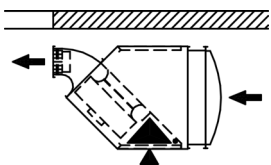

#### **Caution:**

The unit has been manufactured specifically for the installation position indicated in the type code. The unit **cannot** be located in another position.

CODE	INSTALLATION POSITION	EXAMPLE
0	horizontal, above door	
1L	vertical, next to door, on left, at right angle to wall	
1R	vertical, next to door, on right, at right angle to wall	
2L	vertical, next to door, on left, along the wall	
2R	vertical, next to door, on right, along the wall	
←	= direction of air inlet and discharge (must remain unobstructed)	
▲	= inspection side (must be accessible)	
▲▲	= electronic housing	

 Biddle bv Markowei 4 NL-9288 HA Kooilsterlie Made in the Netherlands 	Type	XX XX-XX-XX		
	Code	xxx	U	xxx V xN- xx Hz
	N°	xxxxxx/x-x xx-xx	I <sub>max</sub> L1	xxx A
			I <sub>max</sub> L2	-
			I <sub>max</sub> L3	-
	M	xx kg	P <sub>motor</sub>	xxx kW
Medium	XXXX	P <sub>heating</sub>	-	
	p <sub>max</sub>	xxxx kPa		

### I.3.5 Type plate

The type plate is located next to the discharge grille.

#### Designations on the type plate

DESIGNATION	MEANING
Type	complete type code of the unit
Code	configuration code
N°	serial number, production week and year
M	weight of unit
Medium	medium
P <sub>max</sub>	maximum permissible operating pressure
U	power supply voltage
I <sub>max</sub>	max. current
P <sub>motor</sub>	max. power consumption by fans
P <sub>heating</sub>	<b>For electrically heated models:</b> max. power consumption by heating element

### I.3.6 Field of application

Observe the following limits for the unit:

#### Application limits for all models

Ambient conditions	Temperature	5 °C to 40°C
	Relative air humidity	20% – 95%, non-condensing
Power supply voltage		see type plate
Power		see type plate
Maximum discharge temperature		60 °C

#### Parameters of use for water-heated models

Heating medium	water with max. 50% glycol
Maximum operating pressure	see type plate

**Maximum water flow-paths (unregulated)**

TYPE OF UNIT	MAXIMUM PERMITTED DISCHARGE TEMPERATURE	MAXIMUM WATER FLOW-PATH (UNREGULATED)
H1	60 °C	100/80 °C
H2	60 °C	70/50 °C

**Maximum water flow-paths (regulated)**

TYPE OF UNIT	MAXIMUM PERMITTED DISCHARGE TEMPERATURE	MAXIMUM WATER FLOW-PATH (REGULATED)
H1	60 °C	125 °C/16 bar*
H2	60 °C	125 °C/16 bar*

**Caution:**

\* A water flow-path up to 125 °C/16 bar is only permitted if all units connected have been set in such a way that the maximum discharge temperature is not exceeded **at the lowest fan speed**.

**Note:**

Consult Biddle if you want to connect a unit to a water flow-path with higher temperatures and higher pressure.

**Warning:**

The air curtain may not be used in potentially explosive environments.

**Warning:**

Electrical models may not be used in wet environments.

**Biddle shall not be held liable for damage caused by use in such situations.**

### Sound levels

	MAXIMUM SOUND PRESSURE LEVEL $L_p$ [dB(A)]	MAXIMUM SOUND POWER LEVEL $L_w$ [dB(A)]
IndAC <sub>2</sub> ST-150	61	77.8
IndAC <sub>2</sub> ST-200	62	79.1
IndAC <sub>2</sub> ST-250	63	80.1
IndAC <sub>2</sub> MX-150	69	85.6
IndAC <sub>2</sub> MX-225	71	87.4

$V = 2500 \text{ m}^3$ ;  $T60 = 0.8\text{s}$ ;  $R = 5\text{m}$ ;  $Q = 4$



#### **Warning:**

Prolonged exposure can cause damage to the hearing. If necessary, wear hearing protection.

### Maximum number of units that can be daisy chained

Take into account the maximum number of units that can be daisy chained as shown in the table below:



#### **Caution:**

**With Auto type unit:** The total cable length between the first and the last unit may be 100m at maximum.

	INDAC <sub>2</sub> ST	INDAC <sub>2</sub> MX
Basic	5 m total length (10 fans)	7.5 m total length (10 fans)
Auto	10 units	10 units
Basics per Auto	2 units	2 units



#### **Note:**

Consult your Biddle advisor if you wish to connect more units.

### I.3.7 CE declaration

The unit is compliant with the applicable CE standards. The complete CE Declaration of Conformity can be found at: [www.biddle.info](http://www.biddle.info).

### 1.3.8 Modifications and changes

Without the approval of Biddle, no changes or modifications may be made to the unit that could adversely affect safety. The CE declaration is no longer valid if the unit has been modified or changed in any way.

## 1.4 Components and accessories

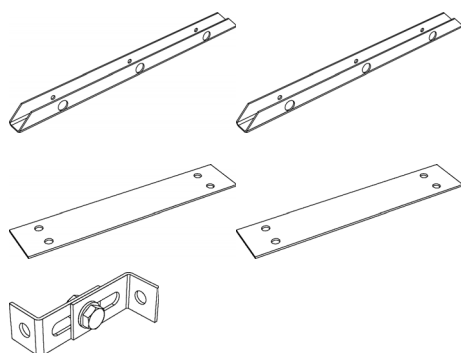

### 1.4.1 Components supplied

#### For horizontal installation:

- suspension rails (2 per unit), also used for fixing the unit to the pallet;

#### For vertical installation:

- coupling plates (2 per unit)
- safety hanger

#### For electrically heated models (type E):

- Biddle control cable for connecting multiple units.



**Note:**

For delivery purposes, some components may be packed within the unit (behind the inspection panel).

### 1.4.2 Operating package

The unit can be supplied with a basic control or an automatic *CHIPS* control. A corresponding operating package is supplied.

#### Operating package for basic control

- *b-control* continuously variable controller.

#### Operating package for automatic *CHIPS* control

- *b-touch* control panel;
- Biddle control cable;
- outdoor temperature sensor;
- door contact switch;
- water-side control (valve and drive).

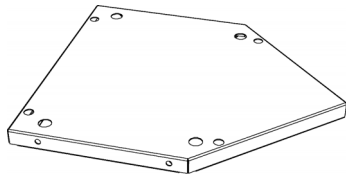

### 1.4.3 Accessories

- plastic side shields;
- base plate (recommended in the event of vertical installation);
- flanges;
- filter module;
- room sensor for automatic *CHIPS* control;
- door contact switch.



**Note:**

For models with automatic *CHIPS* control, the door contact switch is part of the control package as standard.

### 1.4.4 Components not supplied

The following components required for installation must be obtained from third parties:

- threaded rods (M12)
- other cabling

## 1.5 Safety instructions

### 1.5.1 Safety in use



**Warning:**

Do not put any objects into the inlets and outlets.



**Warning:**

Do not obstruct the unit's inlets or outlets.



**Warning:**

The upper surface of the unit becomes hot during operation.



**Caution:**

In exceptional situations, water may run out of the unit. Therefore, do not place anything under the unit that could be damaged by this.

### 1.5.2 Safety issues relating to installation, maintenance and servicing

**Danger:**

The unit may only be opened by qualified technical staff.

**Warning:**

Perform the following actions before opening the unit:

1. Switch the unit off, using the control panel.
2. Wait until the fans have stopped.

**Danger:**

The fans may continue rotating for a while.

3. Allow the unit to cool down.

**Caution:**

The heat exchanger or, as the case may be, the heating elements, may get very hot.

4. Disconnect the mains supply ( set the isolation switch to OFF).
5. **For water-heated models:**  
shut off the central heating feed (if possible).

**Warning:**

The fins of the heat exchanger are sharp.



# 2 . . Installation



**Warning:**  
Installation activities may only be performed by technical staff qualified for this purpose.



**Warning:**  
Before starting installation: read the safety instructions.

**See also:**

1.5 "Safety instructions" on page 15

## 2.1 Inspection on delivery

- Check the unit and the packaging to ensure that they have been delivered in good order. Notify the driver and the supplier immediately if any shipping damage is detected.
- Ensure that all components are present. Notify supplier of any missing parts immediately.

**See also:**

1.4 "Components and accessories" on page 14

## 2.2 General working method

### 2.2.1 Sequence of operations

Biddle recommends working as follows when installing the unit:

1. Hang the unit up. **(horizontal models)**
2. Position the unit. **(vertical models)**
3. For water-heated models **(type H)**:  
connect the unit to the central heating system.
4. Connect the unit to the mains supply.

5. Install the control panel and (any optional) connections to external controls.
6. Complete the installation of the unit.
7. Switch the mains supply on and check that the unit is working properly.

### General instructions

Some parts of this section only apply to certain models. Where this is the case, it will be indicated. If no specific model is referred to, then the description applies to all models.



**Note:**

Make sure that you perform all installation operations that are applicable to your unit.

Check the type plate and consult the manual if in doubt about the model or type of your unit.



**Note:**

During the installation period, protect the unit against damage and penetration of dust, cement, etc. You can, for instance, use the packaging for protection.

## 2.3 Suspending the unit horizontally

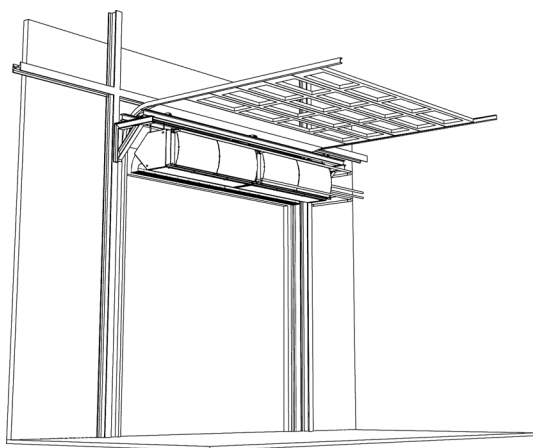

Only with installation position type 0

**See also:**

- 1.3.3 "Type designation" on page 8
- 1.3.5 "Type plate" on page 11
- 1.3.4 "Installation positions" on page 9

Example of an auxiliary structure

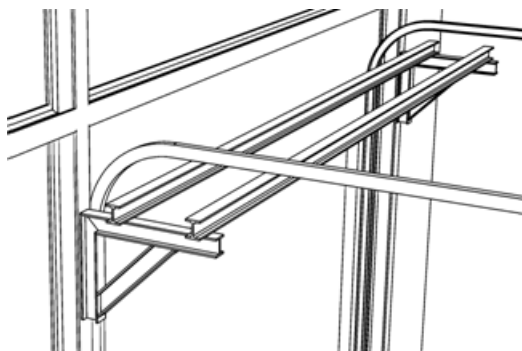

### 2.3.1 Suspension method

This manual assumes that the unit will be suspended from an auxiliary structure, consisting of two horizontal beams positioned above the door.

You may also fix the units directly to the ceiling, or to another horizontal structure, using the screw holes in the upper side of the unit.



**Warning:**  
Make sure that the structure from which the unit is about to be suspended can bear at least 4 times the weight of the unit.

### 2.3.2 Determining the location of the unit

- Position the underside of the unit at the same height as the top of the doorway.
- Position the discharge side of the unit as close to the doorway as possible, to ensure optimum operation.



**Note:**  
If the distance is greater than 5 cm, Biddle recommends that you seal off the openings at the side. For this purpose, you can order a side shield of plastic strips from Biddle.

- Position the row of units centrally in relation to the doorway.
- In the case of an assembly with automatic *CHIPS* control and several units, only one of which is equipped with a control circuit board, position the unit with the control circuit board in the middle of the row.
- Units of different widths can be positioned in random order.
- Make sure that the inspection and intake sides of the units remain accessible for maintenance.



**Warning:**  
Make sure that all units can freely take in and blow out air across their entire width

### 2.3.3 Suspending the unit

Perform the following actions for each unit:

1. Lay the unit in a horizontal position.
2. Fit threaded rods **1** (M12) in all screw holes on the top of the unit.
3. Provide all threaded rods with lock nuts **2**, and tighten them.



**Note:**

The threaded rods must be secured, otherwise the unit may fall down.

4. Fit lock nuts **3** to each threaded rod.
5. Bring the unit into position using lifting equipment.
6. Put the suspension rails **4** on the auxiliary structure, and fasten them with nuts **5** to the threaded rods of the unit.
7. Allow the unit to hang freely.



**Note:**

**For electrically heated models (type E):**

Remove the small side plates **6** from the cable tray between the units, so that the cabling can be drawn through.

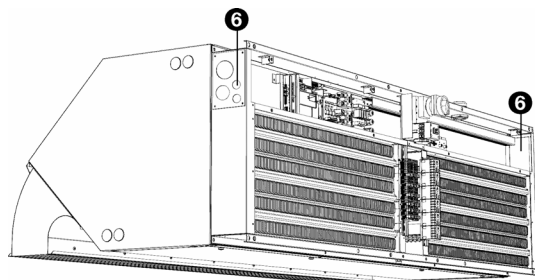
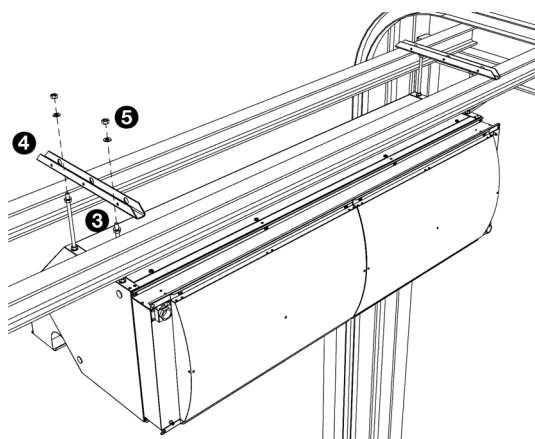
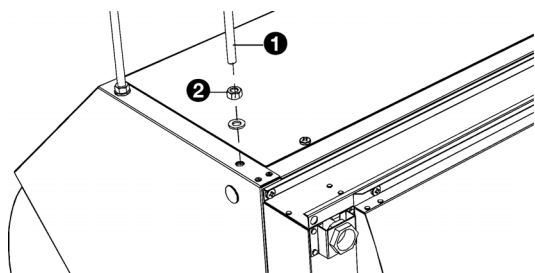

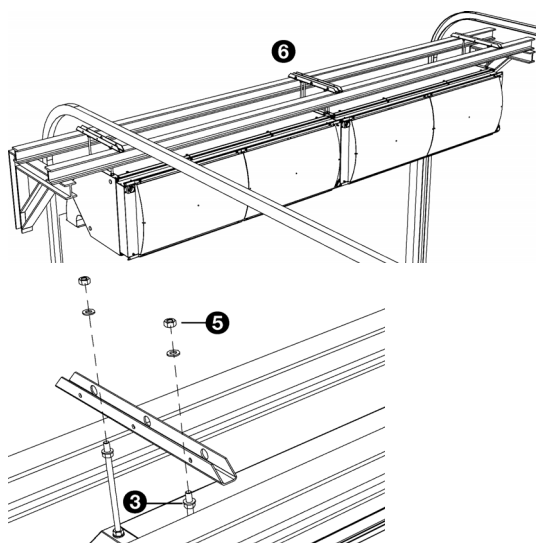

### 2.3.4 Adjusting and securing

1. Position the units against one another, in one line, by placing the suspension rails ⑥ against one another.
2. Attach the suspension rails to the auxiliary structure.



**Warning:**  
Make sure that the suspension rails can never come loose from the auxiliary structure.

3. Adjust the units to the same height, and level them by tightening the nuts ⑤.



**Caution:**  
Ensure that the units are hanging level and horizontal in both directions. Otherwise the fans may run out of true.

4. Secure the suspension to the threaded rods by tightening the lock nuts ③.



**Warning:**  
The threaded rods must be secured, otherwise the unit may fall down.

5. You can possibly fasten the units to each other.



**Caution:**  
First position the units independently of each other, so that no force is exerted on the coupling elements.

### 2.3.5 Installing side shield

For optimum operation, the unit's discharge opening must be placed as close as possible to the door opening. If the distance is greater than 5 cm., you are advised to seal off the openings at the side.

For this purpose, you can order a side shield of plastic strips from Biddle.

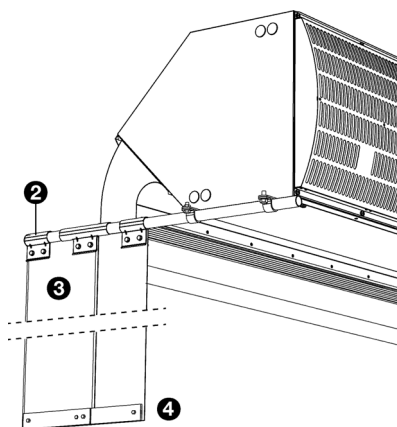
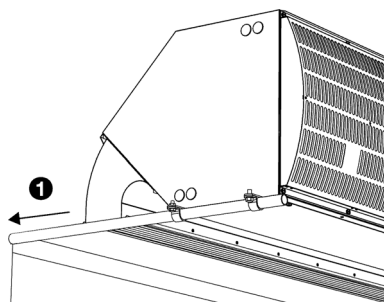
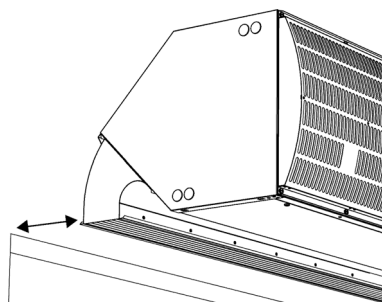

1. On both sides of the unit, mount a tubing profile, reaching to the wall ❶.
2. Cut the plastic strips to size.
3. Fasten the suspension plates above the strips ❷.
4. Fasten the strips to the suspension system ❸.
5. Fasten the steel plates at the bottom of the strips ❹.

## 2.4 Installing the unit vertically

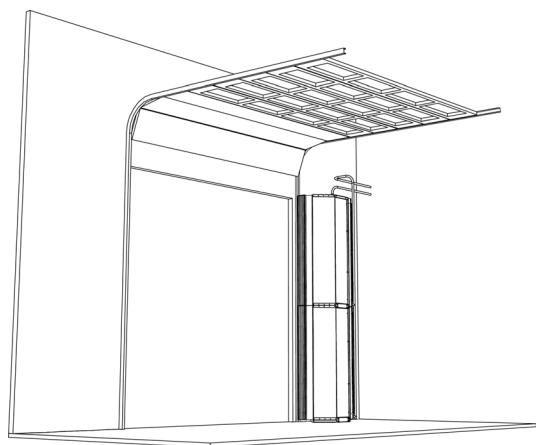

Only with installation positions type 1 and 2

#### See also:

- 1.3.3 "Type designation" on page 8
- 1.3.5 "Type plate" on page 11
- 1.3.4 "Installation positions" on page 9

### 2.4.1 Method of erection

This manual makes the assumption that the unit is to be placed on a base plate (accessory). The units are stacked on top of one another.



**Caution:**

If you do not use a base plate, you must ensure that the surface underneath is horizontal and completely level. Otherwise the fans may run out of true.



**Caution:**

Although the units can stand up by themselves, it is always necessary to secure them to the wall.

### 2.4.2 Determining the location of the unit

- Place the units, depending on the type, on the left or right hand side of the door. For this, consult the type code.



**Caution:**

Do not install the unit in a position other than that for which it was made.

- Position the discharge side of the unit so that its breadth coincides with that of the doorway.
- Position the discharge side of the unit as close to the doorway as possible, to ensure optimum operation.
- Units of different sizes can be placed on each other in random order.
- Make sure that the intake side and the inspection side of the units remain accessible for maintenance.



**Caution:**

Make sure that all units can freely take in and discharge air across their entire height.

**See also:**

1.3.3 "Type designation" on page 8

1.3.4 "Installation positions" on page 9

### 2.4.3 Positioning the units

1. Position the base plate ❶ and fix it to the floor.



**Caution:**

Ensure that the base plate is level.

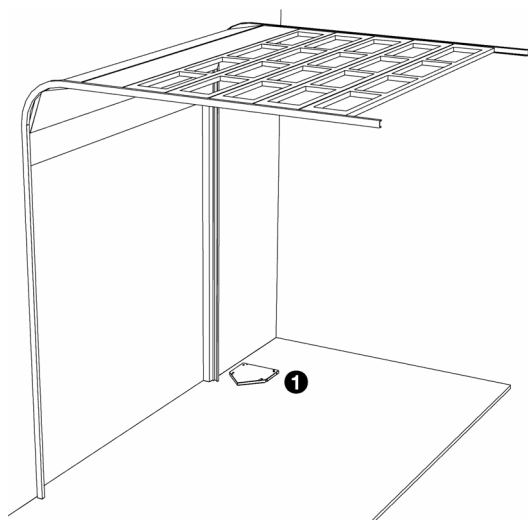

2. Position the first unit on the base plate.
3. Fix the unit to the base plate with coupling plates ❷.



**Caution:**

Mount the coupling plates on both sides of the unit.

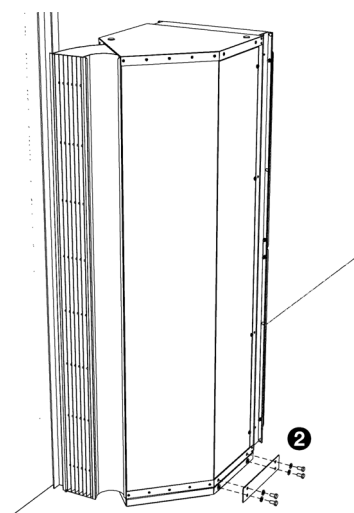

4. Place the second unit on the first unit, and attach them together with coupling plates ❸.



**Caution:**

Mount the coupling plates on both sides of the unit.

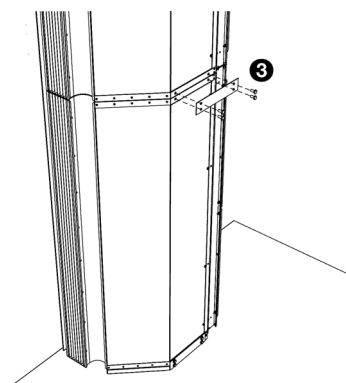

5. Place the third unit (if applicable) in the same way.



### 2.4.4 Securing

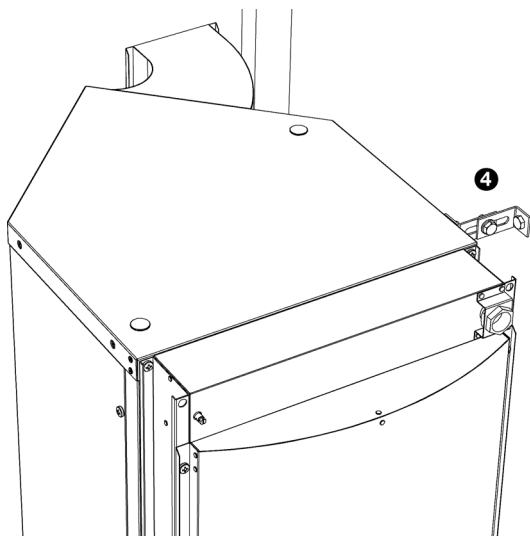

1. Attach the topmost unit safety hanger ④: use one of the screw holes in the unit.
2. Attach the safety hanger to a wall or other fixed construction.



**Caution:**  
If you attach more than 3 units together:  
attach a safety hanger every 2 or 3 units.

## 2.5 Connecting the unit to the central heating system

Only for water-heated models (type H)

See also:

1.3.5 "Type plate" on page 11

1.3.3 "Type designation" on page 8

### 2.5.1 Special points regarding the water connection

The central heating system's supply and return pipes must be attached to the correct corresponding connectors. On the unit, the directions are indicated with arrows.

SYMBOL FEED PIPE	SYMBOL RETURN PIPE
arrow points towards the connection	arrow points away from the connection



**Caution:**  
Biddle recommends the inclusion of a valve in both pipes.

**Danger:**

Take measures to limit the discharge temperature.

Take account of the critical discharge temperatures and water flow-paths. The application limits for this are shown in section [1.3.6 Field of application](#).

**Note:**

The central heating system must be fitted with an overpressure cut-out with an initial pressure not exceeding the permitted pressure of the unit. This is shown on the type plate at  $P_{max}$ .

**Note:**

Make sure that the central heating system has sufficient capacity.

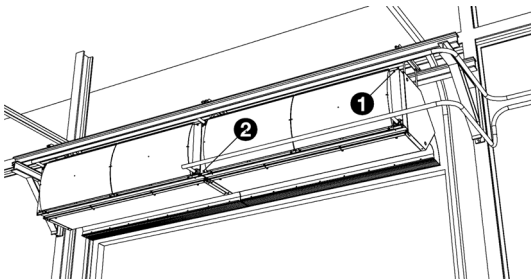

Valves for venting ① and for draining ② of the heat exchanger are located on the intake side.

**See also:**

[1.3.6 "Field of application" on page 11](#)

**2.5.2 The water-side control (accessory)****Only for models with automatic CHIPS control**

The unit is equipped with a water-side control. This regulates the water supply to the heat exchanger, so that a constant discharge temperature is achieved. The control can also be used to limit the discharge temperature. The maximum permitted discharge temperature is indicated in [1.3.6 Field of application](#). For models with automatic CHIPS control, this limitation is automatically set.

**Note:**

In an assembly with automatic CHIPS control, the water-side control valve is automatically closed by default if the unit and/or the heating is switched off. This can be adjusted on the control panel via [menu > Configuration > 45. Extra frost protection](#).

### Special points regarding the water-side control

Biddle supplies water-side controls for models with automatic *CHIPS* control.



#### **Caution:**

A maximum of 3 units having a control valve can be connected in series per control circuit board. Consult Biddle if you want to connect more control valves in an assembly with a single control circuit board.

Control valves that are not supplied by Biddle must, in any case, comply with the following:

- 24V power supply.
- 0-10V control.
- The total power consumption of the water-side controls that are connected to 1 control circuit board may be a maximum of 7.6 VA.

### Connecting the water-side control

#### **Only for models with automatic *CHIPS* control:**

1. Connect the control valve and the drive to the heat exchanger, in accordance with the diagram. In doing so, follow the instructions given in the control valve manual.



#### **Note:**

Ensure that the axis of the valve is in the correct position when connecting the drive. See the control valve manual.

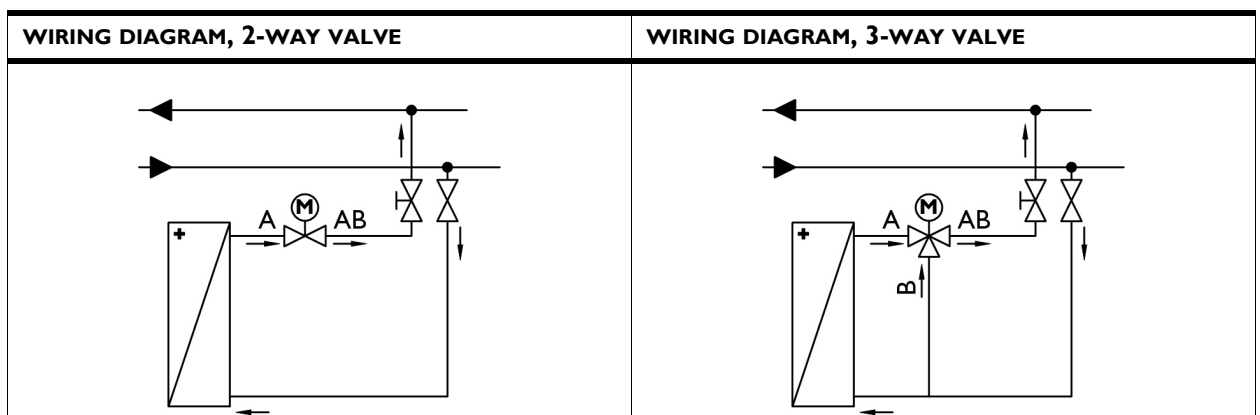

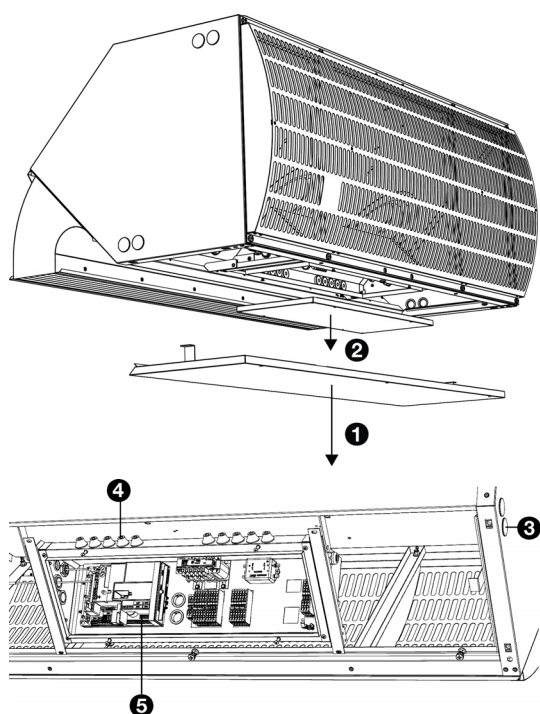

2. Remove the inspection panel ❶.
3. Remove the cover of the electronic housing ❷.
4. Connect the cord to the drive, in accordance with the wiring diagram.



**Note:**  
Use a cable of at least 0.5 mm<sup>2</sup>.

5. Feed the cord from the drive through openings ❸ and ❹ in the electronic housing.
6. Connect the cord to terminal X377 ❺ of the control circuit board, in accordance with the wiring diagram.
7. Connect (if applicable) the drive among multiple units. In doing so, follow the instructions in the drive manual.



**Note:**  
Only close the electronic housing after connecting the mains supply and the control unit and possible external controls.

#### See also:

1.3.6 "Field of application" on page 11

2.5.1 "Special points regarding the water connection" on page 25

### 2.5.3 Frost protection

#### For models with automatic CHIPS control (Auto type)

The electronic control features integrated frost protection. This works in two stages:

1. If the temperature of the discharged air falls to below 5 °C and the temperature of the intake air falls below 8 °C:
  - the valve of the integral water-side control will open fully;
  - the output on the unit gives a signal for the central heating installation provided that function 61. [Function of outputs](#) on the control panel is set to [Risk of freezing](#).

2. If the temperature of the discharged air falls to below 2 °C and the temperature of the intake falls below 8 °C:
  - the control panel will temporarily display error message E6;
  - the fans will be switched off, but the valve of the water-side control will stay open.

**Caution:**

The frost protection reduces the risk of freezing but does not guarantee complete protection.

Take the following precautions if you install the unit in a room where frost may occur:

- Ensure constant circulation of the water at the right temperature;
- Add up to 50% glycol to the water when the unit is not in operation during the wintertime;
- Or bleed the system and the unit.

#### 2.5.4 Connecting the unit

1. Connect the unit to the central heating system.
2. Vent the heat exchangers.
3. Check the connections for leakage.

## 2.6 Connecting the unit to the mains supply

### 2.6.1 Special points regarding the mains supply

For all models

**Warning:**

The unit must be earthed.

**Warning:**

The unit must be connected in accordance with the applicable local requirements.

Maximum ratings are specified on the type plate.



**Warning:**  
Each unit must be fused in accordance with the table below.

#### Fuse ratings

TOTAL MAXIMUM AMPERAGE OF ALL UNITS ON A SINGLE MAINS POWER CABLE. (PER UNIT, INDICATED ON TYPE PLATE L1, L2 OR L3)	MAXIMUM FUSE VALUE A
≤ 10A	16A
≤ 20A	25A
≤ 25A	35A
≤ 35A	50A
≤ 50A	63A
≤ 65A	80A
≤ 80A	100A
≤ 102A	125A



**Note:**  
A single fuse may only be used for multiple units if they draw a total current of less than 10A.



**Note:**  
The earth leakage circuit breaker (if applied) must be **type B**, preferably 300 mA.

#### For all models



**Danger:**  
**Only carry out the connection if you are qualified to work on three-phase power systems.**

- The unit is connected to the mains supply with a cable (5-core, not supplied).



**Caution:**  
For emergency situations and maintenance, it must be possible to render the entire system electrically dead.

- **For electrically heated models (type E)**

Every unit has an isolation switch in order to make maintenance easier.



**Warning:**

Also, do be sure to switch off the mains supply if you are going to conduct maintenance on, or make repairs to, electrical components.

- **For models without heating (type A) and water-heated models (type H)**

An isolation switch (not supplied) must be fitted between the unit and the mains supply. This switch must:

- be all-pole,
- have a contact separation of at least 3 mm,
- be positioned near the unit.

## 2.6.2 Connecting the unit (types A and H)

Only for models without heating and for water-heated models:

### General



**Warning:**

Before you begin: read the special points regarding the mains supply.

**See also:**

2.6.1 "Special points regarding the mains supply" on page 29

### Connecting the unit

Connecting the unit is carried out in the same way for each installation position. With vertical installation position 2, the inspection panel is located in a different position.



**Warning:**

Make sure that the mains supply is switched off.



**Warning:**

The mains power cables must be resistant to the high temperatures in the unit. See [1.3.6 Field of application](#) for the maximum temperatures.

cabling in the case of horizontal installation position  
(type 0)

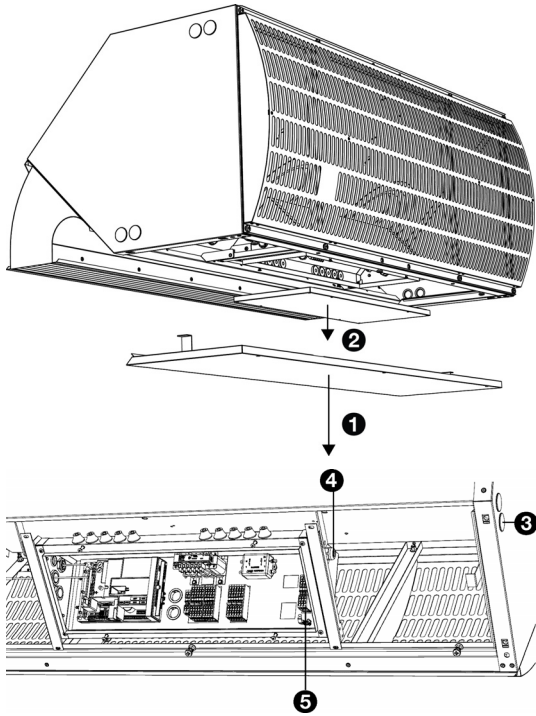

1. Fit an isolation switch between the mains supply and the assembly. For the specifications of the isolation switch, see [2.6.1 Special points regarding the mains supply](#).

2. Remove the inspection panel **1** from the free side of the unit.

3. Remove the cover of the electronic housing **2**.

4. Feed the mains power cable between the isolation switch and the electronic housing in the unit

- In the feed-through hole to be used **3**, fit a cable gland for pull relief.
- You may feed the cable inward through either end of the row of units, as you choose.
- Fasten the cable to the edge inside the unit, using the cable clips.



**Warning:**

**Do not allow the cable to lie or hang loosely.**

5. Feed the cable into the electronic housing.

- Make the grommets **4** in the electronic housing to measure.
- Feed the cable through the wall of the electronic housing.



**Caution:**

Ensure that the grommets fit so tightly around the cable that they remain watertight.



**Warning:**

**Make sure that the earth wire is longer than the power supply wires.**



**Warning:**

**Only for IndAC<sub>2</sub> MX:**

**High leakage current! Connect the earth wire first, before connecting the power supply.**

**Minimum diameter of the earth wire:**

**10 mm<sup>2</sup> / 6 AWG.**



6. Connect the mains power cable to terminal block X01 , in accordance with the wiring diagram.



**Caution:**

Keep the length of the cable within the electronic housing as short as possible. Ensure that the cable does not come into the vicinity of the other cables in the electronic housing.



**Caution:**

Do not switch on the mains supply yet.

### Connecting multiple units

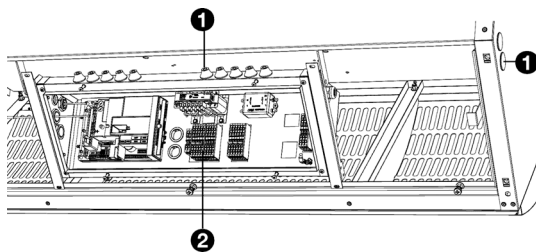

1. Lay the connecting cable between the electronic housings of the units to be connected

- Feed the cable through the feed-through holes .
- Fasten the cable to the edge inside the units, using the cable clips.



**Warning:**

**Do not allow the cable to lie or hang loosely.**

2. Feed the cable into the electronic housings of both units.
  - Make the grommets in the electronic housing to measure.
  - Feed the cable through the wall of the electronic housing.



**Caution:**

Ensure that the grommets fit so tightly around the cable that they remain watertight.

3. Connect the cable in both units to terminal block X60 .



**Caution:**

Keep the length of the cable within the electronic housing as short as possible. Ensure that the cable does not come into the vicinity of the other cables in the electronic housing.

4. Repeat steps 1 to 3 for each unit to be connected.



**Caution:**

Do not switch on the mains supply yet.

**See also:**

1.2.3 "Related documentation" on page 5

### 2.6.3 Connecting the unit (type E)

#### Only for electrically heated models

##### General



**Caution:**

Each unit is separately connected to the mains supply.



**Warning:**

**Before you begin: read the special points regarding the mains supply.**

##### See also:

2.6.1 "Special points regarding the mains supply" on page 29

#### Opening the heating section

Perform the following actions for each unit:

1. Set isolation switch ❶ on the unit to position 0.
2. Remove the cover ❷.
3. Remove the inlet grille ❸.
4. Remove the cover plate of the cable space ❹.

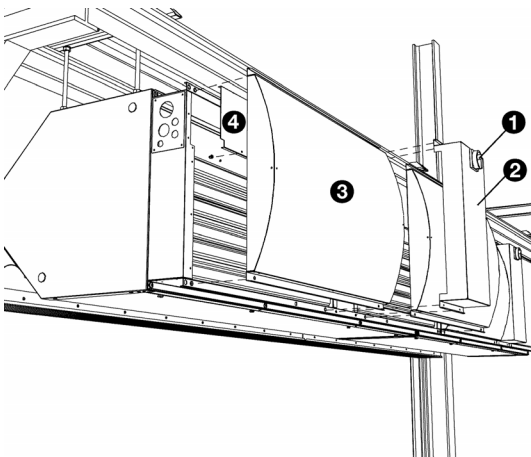

#### Connecting the unit



**Warning:**

**Make sure that the mains supply is switched off.**



**Warning:**

**Connect each unit separately to the mains supply**

Perform the following actions for each unit:

- I. Bring the mains power cable to the unit:
  - Feed the cable through hole ❶.
  - Place the cable in the cable space ❷.

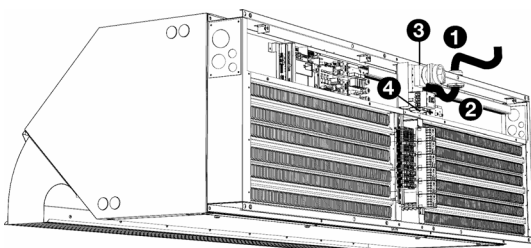

**Note:**

The feed-through hole must be fitted with a cable gland for pull relief.

2. Connect the cable to isolation switch ③, in accordance with the wiring diagram.
3. Connect the earth to the terminal block ④.



**Warning:**

**Make sure that the earth wire is longer than the power supply wires.**

4. Repeat all steps for each unit to be connected.

**See also:**

1.2.3 "Related documentation" on page 5

## 2.7 Installing the *b-control* continuously variable controller

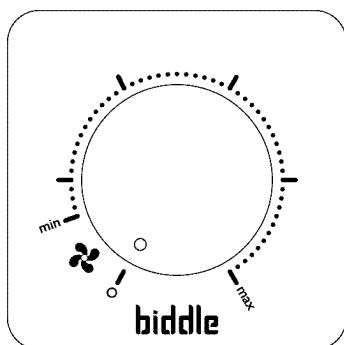

Various control units are available for the IndAC<sub>2</sub> industrial air curtain. This chapter describes the installation of the *b-control* continuously variable controller that is used on units having a basic control (Basic type).

### 2.7.1 Special points regarding the controller

#### Positioning

You can fasten the controller either to the wall or to a standard junction box.

#### Cabling

The controller is connected to the unit via a cable (not supplied), and can be connected in series among several units.

Take the following into account, otherwise errors may occur:

- Keep the length of the cables as short as possible.
- Keep the cables away from electromagnetic fields and interference sources, such as high-voltage cables and fluorescent light starters.

### Multiple units with a single controller

A maximum of 10 fans may be connected to a single controller.

The number of fans in the unit is dependent on the capacity and the length. Indicated in the table is the maximum permissible total length of an assembly with 1 controller.

CAPACITY	MAXIMUM TOTAL LENGTH PER CONTROLLER
IndAC <sub>2</sub> ST	5 m
IndAC <sub>2</sub> MX	7.5 m



**Note:**

Consult your Biddle advisor if you wish to connect more units.

### Setting output voltage

The controller can adjust the strength of the unit in a continuously variable manner. The output voltage can be set between  $V_{min}$  and  $V_{max}$ . This is done after the complete installation of the unit and all connections.

#### 2.7.2 Mounting and connecting the controller



**Warning:**

Make sure that the mains supply on which you are working has been turned off.



**Caution:**

When installing the unit, use the wiring diagram supplied.

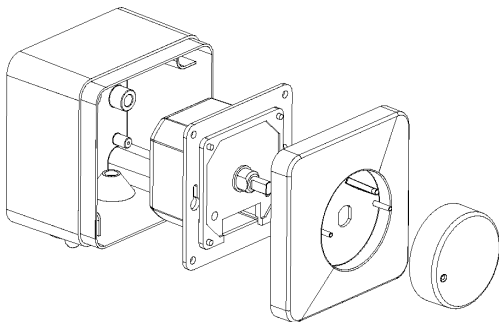

1. Remove the adjustment button.
2. Remove the hexagonal nut.
3. Remove the shut-off cap.
4. Fasten the surface-mounted box to the wall if you are not making use of a standard junction box.



**Caution:**

If IP54 is required and extremely damp conditions are to be expected, a condensation water opening must be drilled on the underside of the surface-mounted box (max. 5 mm).

5. Lead the control cable (not supplied) between the controller and a unit of your choice. For the specifications of the cable, see section [2.7.1 Special points regarding the controller](#).
6. Connect the control cable to the controller. See the wiring diagram supplied.



**Caution:**

Do not turn the controller off yet if you still want to adjust the output voltage after complete installation of the unit.

7. Using the 2 small screws and rings, screw the switch to the surface-mounted box or standard junction box.
8. Fit the shut-off cap.
9. Fasten the hexagonal nut.
10. Fit the adjustment button: Press this on firmly and set to position '0'.

### 2.7.3 Connecting the controller to the unit



**Warning:**

The unit must be earthed.

- I. Lead the cable to the electronic housing in the unit.
  - In the feed-through hole to be used **1**, fit a cable gland for pull relief.
  - You may feed the cable inward through either end of the row of units, as you choose.
  - Fasten the cable to the edge inside the unit, using the cable clips.

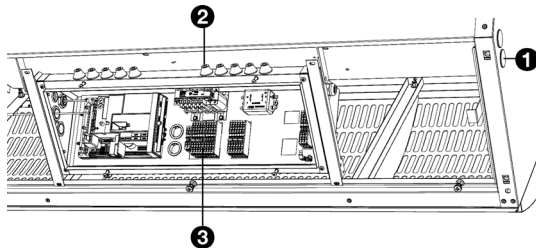

**Warning:**

Do not allow the cable to lie or hang loosely.

2. Feed the cable into the electronic housing.
  - Make the grommets ② in the electronic housing to measure.
  - Feed the cable through the wall of the electronic housing.



**Caution:**

Ensure that the grommets fit so tightly around the cable that they remain watertight.

3. Connect the cable to terminal block X60 ③, in accordance with the wiring diagram.

**Daisy chaining multiple units with a single controller**



**Note:**

Check in 2.7.1 [Special points regarding the controller](#) to see how many units can be connected to the controller.

1. Lay the cable between the electronic housings of the units to be connected
  - Feed the cable through the feed-through holes ①.
  - Fasten the cable to the edge inside the units, using the cable clips.

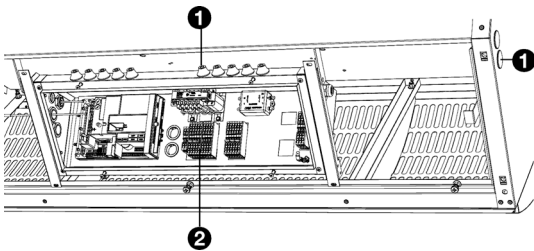

**Warning:**

**Do not allow the cable to lie or hang loosely.**

2. Feed the cable into the electronic housings of both units.
  - Make the grommets in the electronic housing to measure.
  - Feed the cable through the wall of the electronic housing.



**Caution:**

Ensure that the grommets fit so tightly around the cable that they remain watertight.

3. Connect the cable in both units to terminal block X60 ②.
4. Repeat steps 1 to 3 for each unit to be connected.

#### 2.7.4 Connecting an extra controller to the unit (optional)

The fans have a start-up time of approx. 3 seconds. This can be remedied with an extra controller which causes the fans to rotate very slowly if the door is closed.



**Note:**

The fans also continue rotating slowly at night. If this is not desired, switch the unit off at night with the controller that is used for operating it.

You can attach the extra controller to the wall, to a standard junction box or at a spot near the unit.

1. Position the controller in a logical place.



**Note:**

Ensure that there is a clear difference between the extra controller and the controller that is used for the operation of the unit.

2. Connect the controller in accordance with the wiring diagram. In doing so, follow the actions as described in [2.7.2 Mounting and connecting the controller](#) and [2.7.3 Connecting the controller to the unit](#).



**Caution:**

Remove the bridge from between position 5 and position 6 of terminal block X60.



**Note:**

Do not close the controller yet.

## 2.8 Installing the *b-touch* control panel

for the industrial air curtain IndAC<sub>2</sub>, various control units are available. This chapter describes the installation of the *b-touch* control panel, which is used on units having an automatic control (type Auto).

### 2.8.1 Special points regarding the control panel

#### Positioning

- You can fasten the control panel either to the wall or to a standard junction box.



#### **Caution:**

If class IP54 is required, the control panel is supplied in a housing.

#### Cabling



#### **Note:**

Take the following into account, otherwise errors may occur:

- The control cable between the control panel and the (first) connected unit may not be longer than 50 m.
- Keep control cables away from electromagnetic fields and interference sources such as high-voltage cables and fluorescent light starters, for example.
- Lay the control cables out straight or roll them in a bifilar coil by folding cables in half before rolling them. As a result, the magnetic fields will cancel each other out to an important extent.



#### **Note:**

Use Biddle control cables only. Standard modular telephone cable is NOT suitable.

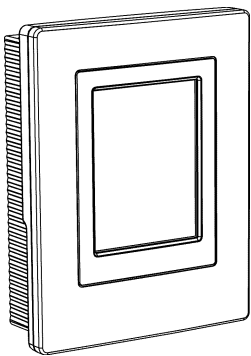



### Multiple units operated from a single control panel

- A maximum of 10 'Auto' units can be connected to a single control panel. And with 'Auto' unit, 2 'Basic' units. The units are thereby daisy chained.
- The total length of the control cables between the first and the last unit must not exceed 100m. If the distance becomes too great, an additional control panel must be connected.
- Only units from the same product series, with the same battery type and of the same capacity can be applied in combination with a single control panel.
- Configure any single unit as the master. The sequence of the connected units is not important.
- Connect the control panel and the external control components to the master unit.



**Note:**

The master unit can be recognised by the addition 'Auto' on the type designation on the type plate.



**Note:**

Do NOT remove the external control input bridges on the other units.

### Operation without control panel

The unit can be operated without control panel. In that event, only remove the control panel after complete installation.

### 2.8.2 Mounting and connecting the control panel

1. Lay the control cable.
2. Slide the control panel out of the wall holder.
3. Connect the control cable to terminal X397.

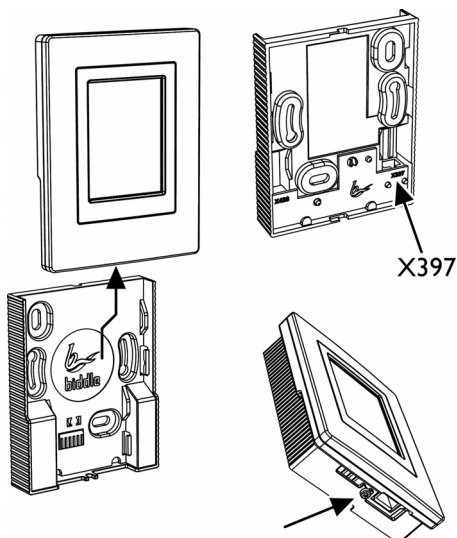

**Caution:**

Ensure that the wall behind the wall holder is even.



**Caution:**

Place the control panel in the housing supplied if class IP54 is required. The openings for the cable guide must be on the bottom.

4. Screw the wall holder onto the junction box or against the wall.



**Caution:**

The control panel should only be put back into the wall holder when the power supply of all the connected units has been switched on.

### 2.8.3 Connecting the control panel to the unit



**Warning:**

**Make sure that the mains supply on which you are working has been turned off.**

#### For water-heated models (type H) and models without heating (type A)

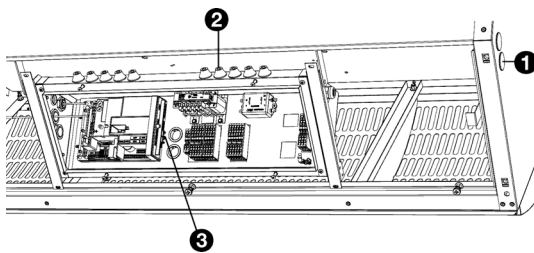

1. Lead the control cable into unit ❶.

- You may feed the cable inward through either end of the row of units, as you choose.
- Fasten the cable to the edge inside the unit, using the cable clips.



**Warning:**

**Do not allow the cable to lie or hang loosely.**

2. Feed the cable into the electronic housing ❷.

- Make the grommets in the electronic housing to measure.
- Feed the cable through the wall of the electronic housing.



**Caution:**

Ensure that the grommets fit so tightly around the cable that they remain watertight.

3. Connect the cable to terminal block X530 ❸, in accordance with the wiring diagram.

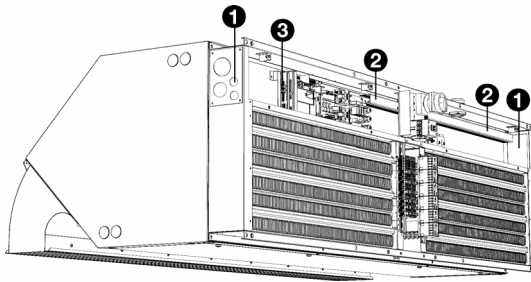

### For electrically heated models (type E)

1. Lead the control cable into unit ❶.
  - You may feed the cable inward through either end of the row of units, as you choose.
  - If necessary, you can interchange or remove the cable guide plates ❶ from the sides of the unit.
2. Lead the cable through the cable tray ❷ if the cable comes in through the right-hand side of the unit.



#### **Warning:**

**Do not allow the cable to lie or hang loosely.**

3. Connect the cable to terminal block X530 ❸, in accordance with the wiring diagram.

### Daisy chaining multiple units with a single control panel

#### For water-heated models (type H) and models without heating (type A):

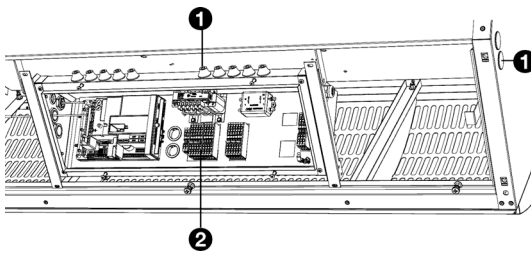

1. Lay the connecting cable between the electronic housings of the units to be connected
  - Feed the cable through the feed-through holes ❶.
  - Fasten the cable to the edge inside the units, using the cable clips.



#### **Warning:**

**Do not allow the cable to lie or hang loosely.**

2. Feed the cable into the electronic housings of both units.
  - Make the grommets in the electronic housing to measure.
  - Feed the cable through the wall of the electronic housing.



#### **Caution:**

Ensure that the grommets fit so tightly around the cable that they remain watertight.

1. Connect the cable in both units to terminal block X60 ❷.
2. Repeat all steps for each unit to be connected.

### For electrically heated models (type E):



**Note:**

For models with electrical heating (type E), use Biddle control cables.

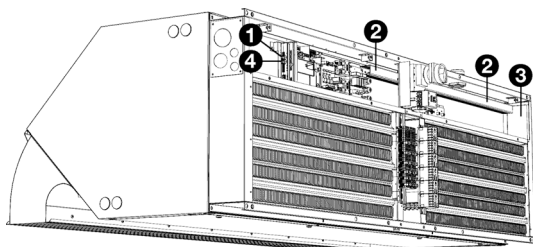

1. Connect the cable in the first unit to terminal block X535 ①.
2. Lay the cable via the cable tray ② and the opening ③ in the side of the unit to the next unit.
  - If necessary, you can interchange or remove the cable guide plates from the sides of the unit.



**Warning:**

Use the cable tray ② in order to keep the cable out of the vicinity of 230V connections.

3. Connect the cable in the second unit to terminal block X530 ④.
4. Repeat all steps for each unit to be connected.

## 2.9 Installing external controls

### 2.9.1 Special points regarding external controls

#### Inputs on the unit i1, i2, i3 (11, 22, 33)

##### Only for models with automatic CHIPS control

On terminal block X520, the unit has three input signal interfaces. The door contact switch (supplied as standard) can be connected to this. Other possibilities include a timer switch, a room thermostat or a signal from a building management system.

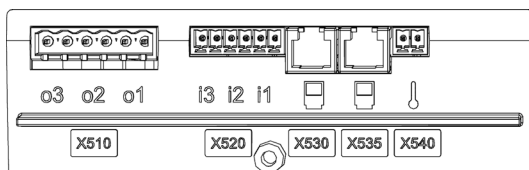

**Caution:**

The inputs are designed for controls with potential-free contacts, and are not to be loaded.



**Caution:**

The inputs of multiple units must NOT be connected to each other.



**Note:**

With the setting **All units off** and with the NC (Normally Closed) settings of function 60. **Function of inputs**, a jumper must be laid on the input for all the subsequent connected units.

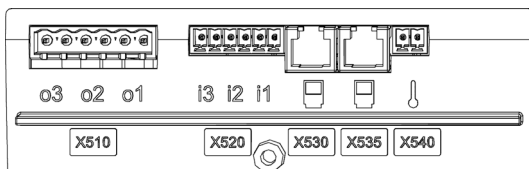

### Outputs on the unit o1, o2, o3

#### Only for models with automatic *CHIPS* control

On terminal block X510, the unit has three signal interfaces for an output signal. These can be used, for example, for controlling the central heating or for transmitting status reports to a BMS.



#### **Caution:**

The outputs are potential-free contacts (relays). Their maximum load is 24 V / 1 A.

### Options and operation

Options and operation depend on the input or output and on the control panel settings.

#### 2.9.2 Installing the outdoor temperature sensor

##### Only for models with automatic *CHIPS* control

The *CHIPS* control requires an outdoor temperature in order to operate correctly. To this end, there are various possibilities.



#### **Note:**

The desired possibility is selected in the installation guide.

1. A wired outdoor temperature sensor
2. A table giving average temperatures per month



#### **Caution:**

The automatic control works less efficiently without an outdoor temperature sensor.



#### **Note:**

If use is made of the table, there is a symbol for the absence of an outdoor temperature sensor on the control panel.

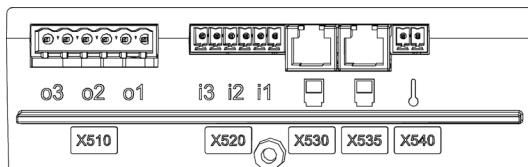
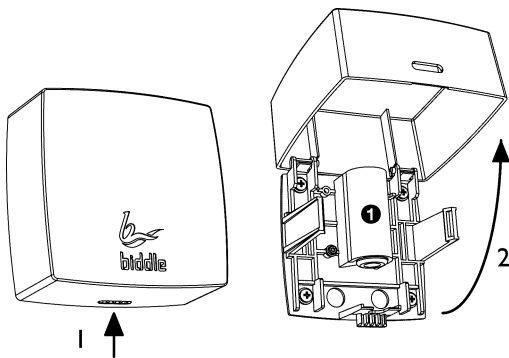
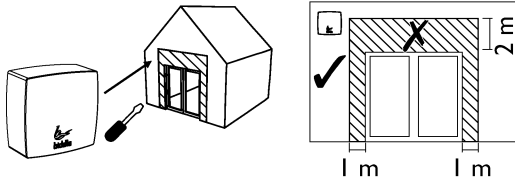

### Position of the outdoor temperature sensor

Mount the outdoor temperature sensor on the outside wall:

- at least 1 metre to the side of the door opening or at least 2 metres above the door opening;
- away from direct sunlight and preferably shielded against rainfall.

### Installing the outdoor temperature sensor

1. Mount the outdoor temperature sensor on the outside wall
2. Lay a cable (not supplied) between outdoor temperature sensor ❶ and unit.



**Note:**

Use a cable of at least 0.5 mm<sup>2</sup>.

Take the following into account, otherwise errors may occur:

- Keep the length of the cable as short as possible.
  - Keep the cable away from electromagnetic fields and interference sources, such as high-voltage cables and fluorescent light starters, for example.
3. Connect the sensor to terminal X540 of the control circuit board in the electronic housing.
  4. When the unit is switched on for the first time, the Installation Guide will start up. This will guide you through the most important settings. During this process, the outdoor temperature sensor will also be installed.

If the Installation Guide does not start up:

- Go to the installation guide via [menu > Maintenance > Installation](#).

### 2.9.3 Installing the room sensor (accessory)

#### For models with automatic *CHIPS* control

The automatic *CHIPS* control works on the basis of the room temperature near the unit. By default, this temperature is measured at the inlet grille of the unit.

In some cases, the temperature in the room differs strongly from the temperature near the inlet grille. This applies in the following situations, for example:

- Draught across the ground;
- If function 45. [Extra frost protection](#) of the control panel is active, heated water is always flowing through the unit.

Biddle recommends installing a room sensor in these situations.

1. Mount the room sensor in the room where unwanted cold or draughts are felt first.

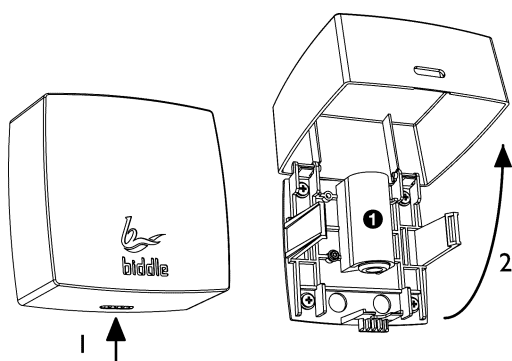

#### **Caution:**

Do not place the sensor in the direct airflow path of the unit.

2. Lay the cable (not supplied) between the room sensor ❶ and the unit.



#### **Note:**

Use a cable of at least 0.5 mm<sup>2</sup>.



#### **Note:**

In an assembly involving several units, connect the cable to the master unit, which can be recognised by the addition 'Auto' on the type designation on the type plate.

Take the following into account, otherwise errors may occur:

- Keep the length of the cable as short as possible.
  - Keep the cable away from electromagnetic fields and interference sources, such as high-voltage cables and fluorescent light starters, for example.
3. Feed the cable into the unit.
  4. Connect the cable to terminal block X64, in accordance with the wiring diagram.

### 2.9.4 Connecting the door contact switch

#### For models with basic control

1. Mount the door contact switch.
2. Connect the door contact switch to terminal block X60, in accordance with the wiring diagram supplied.

#### For models with automatic *CHIPS* control

1. Mount the door contact switch.
2. Connect the door contact switch to input i3 (33) (X520) on the unit's control circuit board.
3. When the unit is switched on for the first time, the Installation Guide will start up. This will guide you through the most important settings. During this process, the door contact switch will also be installed.

If the Installation Guide does not start up:

- Go to the installation guide via [menu > Maintenance > Installation](#).

### 2.9.5 Connecting the alarm signal

#### Only for IndAC<sub>2</sub> MX models.

Units with automatic *CHIPS* control are always equipped with an alarm signal that gives a message in the event of an error in one of the fans.

Units with a basic control can optionally be equipped with this alarm signal.



#### **Caution:**

The contact of a unit which has basic control (Basic type) may be loaded with a maximum of 250 VAC and 2 A.



#### **Note:**

Contact is made only if the unit is connected to a power source and there are no errors.



#### **Note:**

Models IndAC<sub>2</sub> ST do not have any alarm signal options.



### Connecting the alarm signal to the unit

#### For models with automatic control (Auto type)

The alarm signal can be received via an output, ModBus or another building management system. Establish the required connection.

#### For models with basic control (Basic type)

1. Lay the alarm cable (not supplied) between the unit and the appliance on which the alarm signal is received.



**Note:**

If the alarm signal is to be connected in series with several other units: Lay the cable to the unit which is going to serve as the master.

2. Connect the alarm cable to the appliance on which the alarm signal must be received.
3. Connect the alarm cable in the unit to the TK clamps on terminal X15.

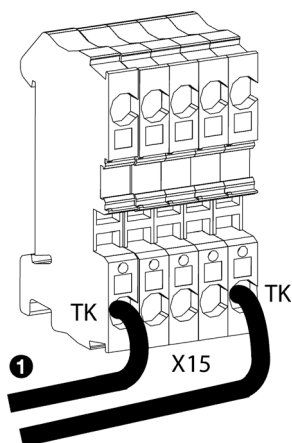

#### Multiple units with a single alarm signal

In a multiple-unit setup, the alarm signal is connected in series between the units.



**Note:**

In a setup consisting only of units having a basic control (Basic type), each unit can also be connected independently to an alarm signal.

1. Lay the alarm cable between the units.
2. Connect the alarm cable to terminal X15 on the first unit to which the alarm signal is already connected (Auto or Basic master):
  - Remove the bridge ②.
  - Connect the cable ③.

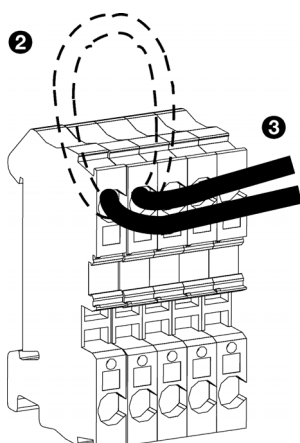

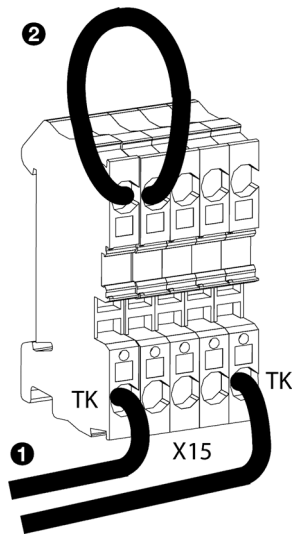

3. Connect the alarm cable in the unit which is to be connected in series to the TK clamps on terminal X15 ❶.
4. Repeat steps 1 to 3 for each unit to be connected in series.



**Note:**

Leave the bridge in place on the final unit ❷.

### 2.9.6 Connecting the unit to Modbus



**Opmerking:**

A detailed manual for the connection and usage of ModBus (and possibly BACnet) is available at:

[www.biddle.info](http://www.biddle.info).

#### Communication parameters

The Modbus system must comply with the following communication parameters:

COMMUNICATION PARAMETER	VALUE
Baud rate	9600
DATA	8
Parity	none
Stop bits	1

The turnaround time between the unit and Modbus is 4.2 msec.

#### Wiring

A twisted-pair cable must be used for connection to the Modbus system. The cable must also have a third core for the GND (grounding). Normally, a four-pole, twisted-pair cable is used; one pair is used for communication and one core from the other pair is used as the GND.

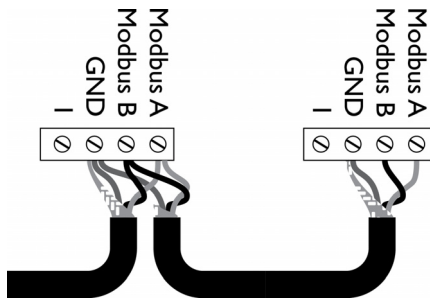

Modbus A = -  
 Modbus B = +  
 GND = ground



**Note:**  
 If there is no communication, this may be caused by incorrectly connected wiring. Swap the A- and B+ wires.

**Connecting the unit to Modbus**

1. Lay a cable between the Modbus system and the unit.



**Note:**  
 In an assembly involving several units, connect the cable to the master unit, which can be recognised by the addition 'Auto' on the type designation on the type plate.

**In the case of BACnet:** Lay the cable between the gateway and the unit.

2. Attach the cable to the unit, in accordance with the wiring diagram supplied:

**In the case of BACnet:** Use the circuit diagram below.

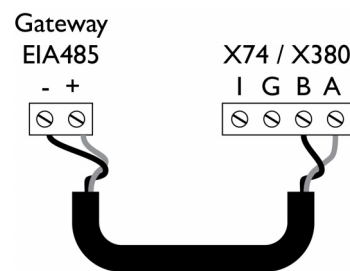
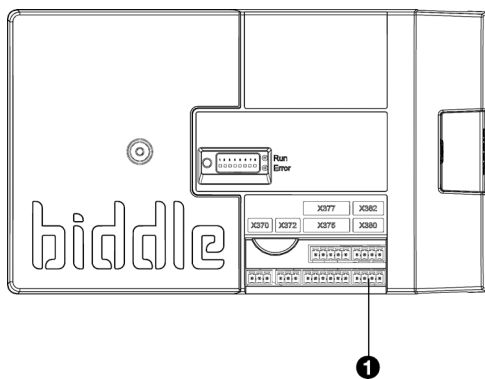

- Feed the cable into the electronic housing.
- Connect the cable to terminal X380 ❶ of the unit's control circuit board.



**Note:**  
 For a more reliable signal, it is possible to connect a 120 Ohm resistor. For this purpose, place a bridge between positions I and B of terminal X382 on the control circuit board in the unit.

**Note:**

The *b-touch* control panel is no longer necessary for purposes of operation. After you have gone through the installation guide, it can be removed. However, do keep it, so as to be able to adjust settings at a later stage.

## 2.10 Finishing the unit

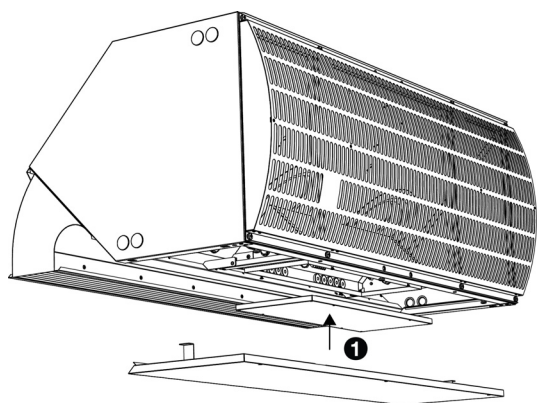

### For units with a control circuit board:

1. Place the cover back on the electronic housing and fasten the screws ①.

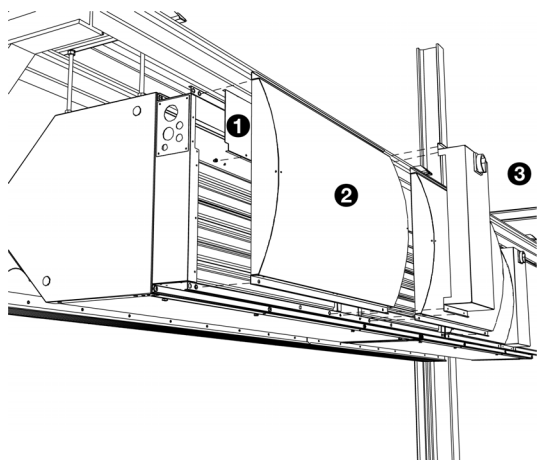

### For electrically heated units:

2. Place cover plate ① back onto the cable space.
3. Put the inlet grilles ② back into place.
4. Replace the cover ③.

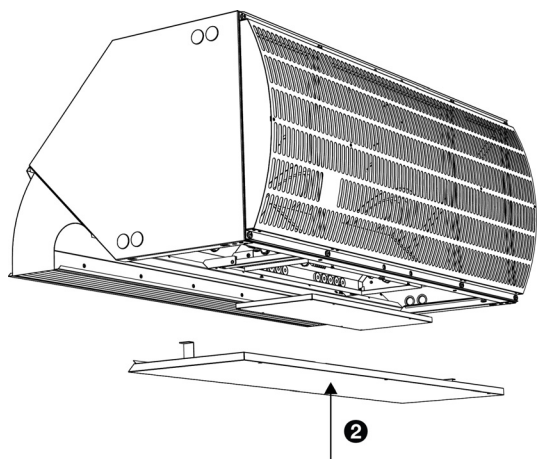

### With all units:

5. Replace the inspection panels ②.

## 2.11 Switching ON and checking operation

### For all models:

#### 1. Check the following connections:

- power supply;
- control cable(s) between control panel and unit(s);
- **If applicable:**  
external control components.

### For all models:

1. Switch the mains supply on.
2. Set the isolation switch to I. (if applicable: on all units)

### For models with *b-control* continuously variable controller

#### 1. If so desired, adjust the output voltage of the controller:

1. Remove the adjustment button.
2. Remove the hexagonal nut.
3. Remove the shut-off cap.
4. Attach a multimeter to 'Vout'.
5. Set the switch to the minimum voltage:
  - Turn the switch all the way to the left;
  - Turn it to the right until the switch clicks;
  - Carefully turn it to the left until you feel resistance, but the switch does not quite click.
  - Set the desired minimum voltage, using a screwdriver.



#### Note:

Set the minimum voltage to at least 2V.

6. Turn the switch all the way to the right.
7. Set the desired maximum voltage, using a screwdriver.



#### Note:

The set max. voltage must be greater than the set min. voltage.

8. Fit the shut-off cap.
9. Fasten the hexagonal nut.
10. Fit the adjustment button: Press this on firmly and set to position '0'.

2. Turn the unit on, using the controller.

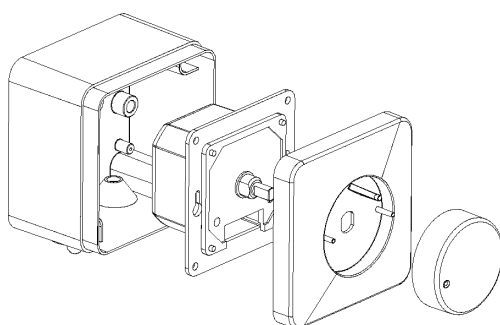

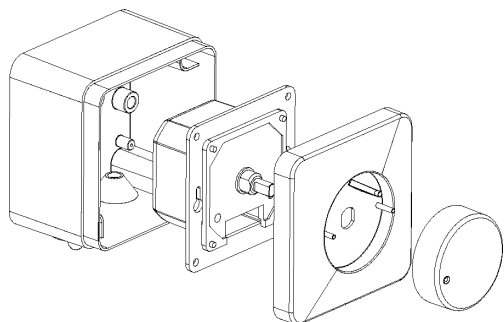

### For models with an extra controller

- I. Adjust the minimal voltage of the extra controller:
  1. Open the extra controller as described above.
  2. Attach a multimeter to 'Vout'.
  3. Set the switch to the minimum voltage:
    - Turn the switch all the way to the left;
    - Turn it to the right until the switch clicks;
    - Carefully turn it to the left until you feel resistance, but the switch does not quite click.
  4. Set the minimum voltage to 1.05V.
  5. Connect the extra controller as described above.
6. Turn the unit on, using the controller that is used for operating the unit.
7. Check the operation of the extra controller:
  1. Open the door. On the first occasion, the unit has a start-up time of approx. 3 seconds.
  2. Close the door.
  3. Check that the fans continue rotating very slowly.
  4. Open the door. The unit should now start up immediately.

### For models with *b-touch* control panel

- I. Place the control panel back into the wall holder.

When you connect the control panel, the control panel searches for connected units and then briefly displays the number of connected units.



#### **Caution:**

If the number of units displayed does not match the number connected, check the wiring and power supply of the units and reconfigure the system via [menu > Maintenance > Reset system](#).

#### **Optional:**

Lock the control panel with the screw on the underside.

During the first start-up, the installation guide is initiated. Go through this in order to make the most necessary settings.

If the installation guide is not displayed, it can be started via [menu > Maintenance > Installation](#).

If the control panel does not work, or if the display shows an error message, there is an error: consult the relevant section.



**Note:**

The settings of the *b-touch* control panel can be copied to another *b-touch* control panel. See [7.10 Copying the settings](#).



**Note:**

After installation, the control panel may possibly be removed. See [2.8.1 Special points regarding the control panel](#) for the conditions.

**For all models:**

1. Check whether the fans are rotating.



**Caution:**

If the fans run out of true, it is possible that the unit is not standing or hanging completely level. Correct this, if necessary.

**For water-heated models (type H):**

1. Check whether the heat exchanger is connected correctly.
2. Make sure that the central heating system has been turned on.
3. *If the b-touch control panel is implemented:* Make sure that the heating is enabled on the control panel.
4. Feel whether the discharged air stream becomes warm. This may take some time and is dependent on the need for heating.
5. Vent the heat exchanger.
6. Adjust the unit on the water side:



**Caution:**

*For models with basic control (type Basic):* Ensure that at the lowest fan speed the maximum discharge temperature is not exceeded. For the maximum discharge temperature, see section [1.3.6 Field of application](#).

**Caution:**

*In the case of a combination of models with a control circuit board (type Auto) and models without control circuit board (Basic): Adjust all units on the water side. Ensure that all units have the same discharge temperature.*

**For electrically heated models (type E):**

1. Make sure that the heating is enabled on the control panel.
2. Feel whether the discharged air stream becomes warm.  
This is dependent on the need for heating.



# 3 . . Operation with *b-control*

Various control units are available for the industrial air curtain IndAC<sub>2</sub>. This chapter describes operation with the *b-control* continuously variable controller that is used on units having a basic control (Basic type).

## 3.1 Introduction

This section describes the functions of the *b-control* continuously variable controller which are necessary for the operation of the unit. The isolation switch on the unit is only needed during maintenance and servicing.

## 3.2 Switching ON and OFF

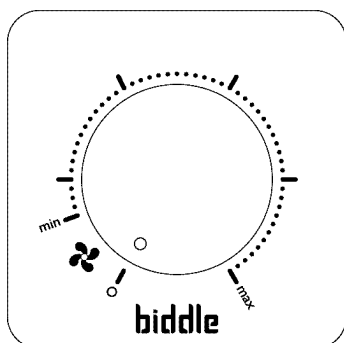

When the controller is set to strength 0, the unit is switched OFF.

Turn the knob of the controller clockwise in order to switch the unit ON.



**Note:**

The unit switches on commencing at the minimum strength 'min'.

## 3.3 Regulating the strength

The fan speed can be regulated in a continuously variable manner with the controller.

The most optimal speed is the minimum strength at which the airflow touches the ground and there is no draught across the ground. This may vary per day and during the course of the day.

# 4. . Operation with *b-touch*

Various control units are available for the industrial air curtain IndAC<sub>2</sub>. This chapter describes operation with the *b-touch* control panel, that is used on units having an automatic control (Auto type).

## 4.1 Introduction

This section describes the functions of the *b-touch* control panel, which are required for setting up the unit.



**Note:**

After installation, the control panel may possibly be removed. See [2.8.1 Special points regarding the control panel](#) for the conditions.

For the purpose of altering setting easily, the control panel can remain present.

### 4.1.1 Control panel

The *b-touch* control panel is equipped with a touch screen (touch screen) with which all the functions can be set:

- Turning the unit ON and OFF;
- Adjusting the strength of the unit;
- Switching the heating ON and OFF;
- Entering settings to adjust the operation of the unit to your situation.

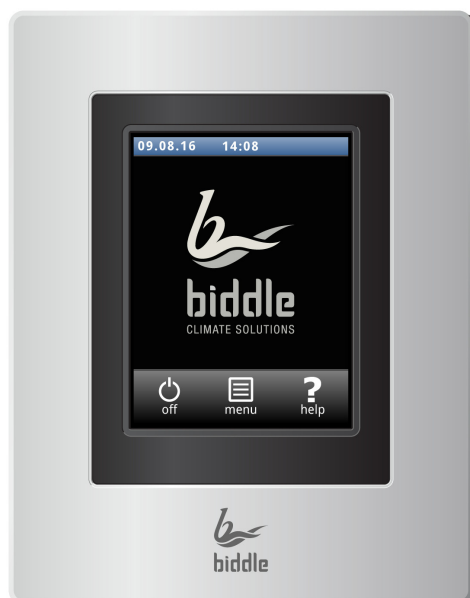

**b-touch**

### 4.1.2 Multiple units operated from a single control panel

If multiple units are connected to the *b-touch* control panel, the settings on the panel are the same for all units.

### 4.1.3 Settings

Select ✓ to save the settings and return to the previous screen.



Select ✗ to return to the previous screen without saving the changes.



## 4.2 The Home screen



The settings of the unit and the room temperature can be adjusted on the Home screen.

- Touch the parts of the symbol to select manual or automatic and to adjust the strength of the unit or the room temperature.
- Touch the airflow symbol to obtain concise information about the operation of the unit.
- Touch **menu** to open the main menu.

### 4.2.1 Help function



At any time, you can call up additional information concerning the point in the operation where you are, by touching Help.

### 4.2.2 Turning the unit ON and OFF

You can switch the unit ON and OFF manually, using the control panel.

- Touch **on/off** in order to turn the unit ON or OFF.

If the unit is on, the screen will become darker after some time, in order to save energy. When the screen is touched, it lights up again. This function cannot be deactivated.

If the unit is switched off, the screen will go black after some time. Touch the screen to activate it again.

# CHIPS

The unit can also be switched ON and OFF in other ways:

- Using external controls (see function [65. Control panel input](#) and [60. Function of inputs](#)).
- Via the internal timer or via an external release signal on the unit.

In these cases, the ON/OFF button can be hidden via [Configuration > 21. User interface options > Display on/off button](#).

### 4.2.3 The CHIPS control

By default, the unit operates with fully automatic control. Depending on the selected settings, the unit can also be controlled manually. In automatic mode, the unit operates under CHIPS control. This control matches the strength and heat of the unit to changing weather conditions. This reduces energy consumption and improves comfort through selection of the optimum setting under all circumstances. CHIPS stands for “Corrective Heat and Impulse Prediction System”. The unit works on the basis of the outdoor temperature and the room temperature near the air curtain.

### 4.2.4 Automatic or manual control

The unit has an automatic mode and a manual mode. You can select these by touching the uppermost part of the symbol. When the unit is switched on, it is always in automatic mode. If you wish to use the unit in manual mode only, switch off the automatic mode via [menu > Settings > 1. Select modes](#).

In the manual mode, the unit operates with a fixed set fan speed, possibly influenced by the settings of function [26. Manual: Door response](#).

### Recommended setting of the unit

To obtain the maximum possible separation effect and the greatest possible comfort with the least possible energy consumption, Biddle recommends use of the fully automatic CHIPS control.

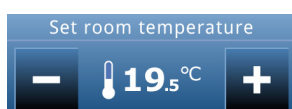
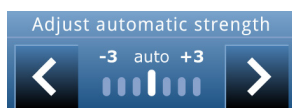

## 4.2.5 Regulating the strength

### Adjusting the automatic strength control

In automatic mode, the strength and temperature of the air-flow are regulated automatically. Due to weather conditions you might want to adjust the automatic setting. If you feel a cold draught along the floor, you can increase the automatic strength.

### Manual setting of the strength

With the manual setting, you can select the strength. To achieve maximum climate separation with minimum energy consumption, Biddle recommends selecting the lowest strength at which no draught occurs. This setting may possibly need to be changed during the course of the day.

## 4.2.6 Required room temperature

You can set the temperature to a comfortable level. This is the temperature at the air curtain.



### Note:

If a room sensor has been implemented, that is the place where the temperature is measured.

Temperature adjustments made via the home screen of the *b-touch* control panel only apply until the starting time of the following period. The default value can be set via [menu > Settings > 5. Room temperature](#).

## 4.2.7 Errors

The symbol  indicates that there is an error. The error message is also displayed alongside.

- Touch this message for further information on the error and for instructions as to how to react.



### Warning:

Some errors may cause damage or danger to persons if they are disregarded. If  is displayed, follow the instructions on the control panel concerning how to act.

**Note:**

The symbol  and the error message remain displayed as long as the error has not been remedied.

If an error has remedied itself, a corresponding message will be displayed. Touch this message to display the [Error history](#) and to read out the errors and the times of their occurrence. This list can also be read out via [Maintenance > Error history](#).

**See also:**

5.2 "Error messages on the control panel" on page 81

**4.2.8 Symbols**



The outdoor temperature sensor absent symbol indicates that the outdoor temperature is based on a monthly average. Only treat this as a error if this is not a deliberate setting.

The symbol  indicates that the timer is switched on.

The symbol 'i' indicates that there is currently a tip to be read. Touch the symbol in order to read the tip.

**4.3 Main menu**

Touch [menu](#) in order to open the Main menu. Here you can enter settings for a number of frequently used functions; in submenus you can enter settings in order to adapt the operation of the unit to your specific situation.

- Touch [home](#) in order to return to the Home screen.
- Using  and  you can browse through the list.

If the control panel is not operated for some time, it returns automatically to the Home screen without saving the changes.

**Lock screen**

Select [Lock screen](#) in order to prevent unauthorised access. The  symbol appears on the screen.

**Unlocking**

Touch the screen for 5 seconds to unlock it.

### Turning the heating on and off



The unit's heating can be switched on and off manually.

Switching the heating off disables the room temperature control and any [Heating on](#) output functions.

This function can be deactivated via setting 21 in the configuration menu.

- Select [Heating](#).

When the heating is switched off, the airflow is displayed in blue.

The heating can also be switched off by the control itself:

- by an external signal on the unit's input, see [menu > Configurationmenu > Configuration > 60. Function of inputs](#), setting [Heating off](#);
- when the outdoor temperature is higher than the setting of function 41. [Heating OFF temperature](#).

### Cleaning display

Using the touch screen can leave marks or fingerprints on the screen. The screen can be cleaned using a damp, soft cloth.

Use this function to disable the touch screen for 20 seconds in order to be able to clean it.

### Timer

The b-touch control panel has a week timer. You can set two start and stop times for each day of the week. The unit is on between the start time and the stop time. The second start and stop times are optional. When the ON/OFF button is displayed on the screen, the unit can also be switched ON or OFF manually. From the next switching moment, the unit follows the timer again. When the timer is switched on, the symbol ☉ is displayed on the Home screen.

## 4.4 Preferences

### Preferences

The menu **Preferences** allows you to make settings for the use of the control panel.

### Set language

The control panel offers a choice of languages. Choose your preferred language from the list.

### Set date and time

The date and time are necessary for the timer function and for tracking usage statistics of the unit.



#### **Caution:**

The date is also required if there is no outdoor temperature sensor or contact sensor connected to the unit. In that case, the CHIPS control estimates the outdoor temperature based on the month of the year and the climate data for your country. An incorrect date causes the unit to work less optimally.

The automatic summer time function switches the clock to summer or winter time in accordance with the applicable European rules. If you do not use this function, you can switch to summer time manually. The clock is then set one hour forward.

### Celsius / Fahrenheit

Choose between a temperature display in degrees Celsius or degrees Fahrenheit.

### Display brightness

Set the brightness of the screen to your personal preferences or to the specific situation.

### Show tips

The control panel can show tips about the usage of the unit. The display of these tips can be enabled or disabled.



## 4.5 Settings

The Settings menu allows you to enter settings which influence the day-to-day use of the unit.

### 1. Select modes

The control panel has an automatic mode and a manual mode. With the function Select modes, you can set which of these modes can be selected in the HOME screen.

### 5. Room temperature

Here, set the temperature which is to be used by default as the room temperature when starting up the unit.

The desired room temperature can temporarily be adjusted on the home screen until the next start-up moment.

### 6. Minimum air temperature

Set the minimum difference between the room temperature and the discharge temperature.

This difference can be increased for more comfort. A smaller difference saves energy.

### 8. Night temperature

The night temperature is used when the unit is switched off. When the room temperature drops below this set value, the unit will start working in order to keep the room at the night temperature.



**Note:**

This function only operates when the heating is switched on.



**Warning:**

**Be aware that the airflow of the unit can set objects in motion. This might set off an alarm system in the building at night time.**

### 9. Calibration

An unfavourable positioning of the room sensor or use of the temperature sensor in the unit may be the reason why the displayed temperature deviates from the actual temperature.

Use this function to adjust the temperature reading.

## 4.6 Configuration

The menu **Configuration** allows you to enter settings in order to adjust the operation of the unit to the room and the system. Usually, this menu is used only for installation, maintenance and service purposes.

### 20. Access control

#### **Pin code**

Access to the entire control panel or to the menu only can be protected with a four-digit PIN code.

The default PIN code is 0000.

#### **Access level**

The control panel can be safeguarded at different access levels.

### 21. User interface options

#### **Display on/off button**

The unit can be switched ON and OFF manually. This can also be done via the internal timer or via an external release signal on the unit. In this case you can disable the manual on/off option. The on/off button is then not displayed on the Home screen.

#### **Temperature display**

By default, the room temperature is displayed. With this function, you can select another temperature to display or switch off the temperature display.

If the temperature display is switched off, there is no temperature control.

#### **Heating OFF option**

Use this function to enable or disable the option which allows the user to switch the heating ON/OFF manually.

#### **Error display**

Some error messages may be caused by external factors such as the central heating system and do not necessarily have an influence on the functioning of the unit.

Use this function to suppress these messages. Safety-related warnings will always be displayed.

## 25. Auto: Door response

### Door response

The unit can respond in various ways to the opening and closing of the door. Configure whether the response should be immediate or gradual.

**Immediate change:** The unit responds immediately to the opening and closing of the door by quickly switching between the fan speeds for the door open situation and the door closed situation. Use this setting if the door is not often opened repeatedly in quick succession.

**Gradual change:** The speed at which the unit responds to the opening and closing of the door is based on the open/closed ratio. If the door opens repeatedly in quick succession, the unit adjusts gradually, so that it does not need to start up completely over and over again and high fan strengths (with attendant noise) are not so necessary. Use this setting if the door is regularly opens repeatedly in quick succession and the changes between low and high fan strengths are undesired.

### Fan speed

Set what the fan speed must be if door is closed. This is also the minimum setting with door open.

If this function is set to 0 (fans off) or 5, then, because of the room temperature control, the fans can nevertheless start working while the doors are closed.

### Room temperature control

If the door is closed, the unit helps to keep the room at the correct temperature controller. If the set fan setting for closed door has been set to 0 or 5, this function does not work.

If room temperature control is indeed desired, the function can still be activated here.

### Fan speed for room temperature control

Set the percentage of the fan speed that must be used for room temperature control if this has been set via menu [25. Auto: Door response](#).

As soon as the room temperature has been reached, the fans switch off.

### Stand-by heating

The control can be set in such a way that heat is immediately available when the door is opened. This is a percentage of the maximum heat available for this function. The maximum heat depends on the outdoor temperature, among other things.

Set the amount of heating that must be available when the door is opened:

- If immediate heat is important, set a high percentage.
- If saving energy is important, set a low percentage.



#### Note:

The room temperature control can affect this amount of available heat.

### 26. Manual: Door response

Set the way in which the unit in manual mode should respond to the opening and closing of the door:

- Direct response.
- No response. (The unit always works on the set fan setting)

### 31. Maximum strength

In order to restrict the sound level, the maximum fan speed can be limited. This function only has effect on the automatic mode.

Use of this function can reduce comfort.

### 32. Deceleration time

You can set a post-rotation time for the fan. Here, set the period of time it should take for the fan to decelerate from maximum speed to standstill.

### 33. Boost function

If there is a great difference between the desired room temperature and the actual room temperature, the fan speed can be increased in order to reach the desired temperature more quickly.

Set the temperature difference at which the boost function should be activated and what the fan's increase in speed should be.

Use this function if the unit is also used for heating the room.

If **61. Function of outputs** is set to value **Risk of freezing**, a contact on that output is also made when the actual temperature is higher than this setting.

### 41/42/43 Operation at higher outdoor temperatures

As the outdoor temperature rises, the need for climate separation and heating changes. In functions 41, 42 and 43 you specify at what outdoor temperatures the heating and the fans must react to this.

SITUATION	NEED	FUNCTION	OPERATION
It is colder outdoors than indoors.	Heated climate separation	Normal operation	Heating: on Fans: on
It is approximately as warm outdoors as indoors.	Ambient climate separation	41. Heating OFF temperature	Heating: <b>off</b> Fans: on
	No climate separation	42. Fan OFF temperature	Heating: off Fans: <b>off</b>
It has become much warmer outdoors than indoors.	Ambient climate separation	43. Temperature unheated usage	Heating: off Fans: <b>on</b>

#### 41. Heating OFF temperature

If the outdoor temperature rises above this point, the unit's heating is switched off.

A higher value gives more comfort, a lower value saves energy.

#### 42. Fan OFF temperature

When the outdoor temperature rises, there is less need for climate separation. In order to save energy, the fans can be switched off at a pre-set outdoor temperature.

Set this value at 50°C in order to leave the fans on all the time.

#### 43. Temperature unheated usage

When the outdoor temperature becomes higher than the desired room temperature, there is a need for climate separation without heating. Set the outdoor temperature at which the unit should function in an unheated mode in order to keep the heat out.

Set this value at 50°C in order to leave the temperature control on all the time.

#### 44. Outdoor temperature

The automatic CHIPS control needs an outdoor temperature in order to calculate the optimal setting. Without temperature data from a sensor, the outdoor temperature is estimated on the basis of the month of the year and your country. Climate data are used for this.

You can only use the function if the date and time have been correctly set. After selecting your country, you can modify the monthly temperatures in accordance with your wishes. Since this is only an estimation, it may be that your unit does not function optimally.



**Note:**

The automatic control works less efficiently without an outdoor temperature sensor.

#### 45. Extra frost protection

##### For water-heated models only

When the unit is switched off, the water valve closes by default.

By default, the unit is equipped with frost protection. You can additionally protect the unit against frost damage by leaving the water valve partially open at certain temperatures.

Select **Valve position** and set the opening percentage of the valve so as to always keep a flow running over the heat exchanger in the unit.

Set the maximum outdoor temperature at which the additional frost protection must be activated. When the temperature exceeds this value, the additional frost protection switches off again.

#### 46. Maximum discharge temperature

The controller limits the discharge temperature to a maximum of 50°C. Possibly set a lower value in order to save energy.

#### 47. Overheat protection

If the actual room temperature becomes higher than the pre-set room temperature, the heating can be switched off in order to prevent the room from becoming too warm.

Set the temperature above which the heating must be disabled.



**Note:**

This function can only be used if the unit is set to automatic.



**Note:**

If this function is activated, then function **6. Minimum air temperature** is ignored.

## 50. Installation height

In order to use the automatic control as efficiently as possible and with minimum energy consumption, it is necessary to set the installation height of the unit correctly.

The installation height is the distance from the floor to the underside of the unit.

## 60. Function of inputs

The unit has three inputs (terminal block X520) which can be used to enable a function to be controlled by an external accessory such as a door contact switch, a thermostat or a signal from a building management system.

By default, input 3 is used for the door contact switch.

### Values for inputs 1 and 2

VALUE	OPTION	DESCRIPTION
0	No function	The input has no function.
1	Unit off locally – NO	The unit is switched OFF when the contact is closed. (This only works with the units to which the input signal is directly connected (locally).)
6	Heating off	The heating is switched OFF when the contact is closed.
9	Release – NO	The user is allowed to switch the unit on and off when the contact is closed.
10	Dirty filter – NO	Displays a “dirty filter” warning if the contact is closed.
21	Switch all units on	All units are switched ON when the contact is closed.
51	Unit off locally – NC	The unit is switched OFF when the contact is open. (This only works with the units to which the input signal is directly connected (locally).)
56	Heating on (dependent on software version)	The heating is switched ON when the contact is closed.
59	Release – NC	The user is allowed to switch the unit on and off when the contact is open.
60	Dirty filter – NC	Displays a “dirty filter” warning if the contact is open.
71	All units off	All units are switched OFF when the contact is closed.

The function of input 3 is set via other functions in the *b-touch* control panel. In addition, the function of this parameter (60.3) is controlled via the settings file or via Modbus.

**Values for input 3**

VALUE	OPTION	DESCRIPTION
13	Door contact switch – NO	If the door opens, the contact is closed.
21	Switch all units on	All units are switched ON when the contact is closed.
63	Door contact switch – NC	If the door opens, the contact is opened.
71	All units off	All units are switched OFF when the contact is closed.

**Release delay input 1**

When you use input 1, you can make the effect of an input signal persist for some time after the signal has been given ('release delay'). You can use this setting in combination with a door contact switch, for example, in order to keep the unit running for a while after the door has been closed.

**6.1. Function of outputs**

The unit has a connection (terminal block X510) for three output signals: these can be used for controlling the central heating system, for example, or for transmitting status reports to a Building Management System (BMS).

By default, output 3 is used for error messages.

The outputs work independently of each other.

**Multiple units operated from a single control panel.**

The outputs always have a global effect: the signals are always the same in all units connected to the control panel.

**Values**

VALUE	OPTION	DESCRIPTION
1	Error – NO	The contact is closed as soon as an error occurs.
2	Dirty filter – NO	The contact is closed as soon as the maximum filter lifespan has expired.
3	Heating deficit	The contact is closed when the unit cannot reach the desired air temperature.
4	Error or dirty filter – NO (if filter present)	The contact is closed as soon as an error occurs or when the maximum filter lifespan has expired.
8	Unit on	The contact is closed as soon as the unit is switched on.
10	Error local – NO	The contact is closed as soon as an error occurs in the unit in question.



VALUE	OPTION	DESCRIPTION
11	Fan active – NO	The contact is closed when the fans are running.
13	Heating on	The contact is closed when the unit requires heating. Use this to switch the heating system ON or OFF via the unit.
15	Risk of freezing	The contact is closed when the temperature inside the unit drops below 7 °C.
17	Use boost function	The contact is closed when the difference between the desired temperature and the room temperature is greater than the value set for 33. Boost function.
31	Copy input 1	The output follows the contact on input 1
32	Copy input 2	The output follows the contact on input 2
33	Copy input 3	The output follows the contact on input 3
40	Overheating protection	The contact is opened as soon as the high-limit thermostat has been activated (only for output 3, only for models with electrical heating)
41	Fan malfunction – NC	The contact is opened when there is a malfunction in the fan. (only for output 3, only for types L and XL)
51	Error – NC	The contact is opened as soon as an error occurs.
52	Dirty filter – NC	The contact is opened as soon as the maximum filter lifespan has expired.
60	Error local – NC	The contact is opened as soon as an error occurs in the unit in question.
61	Fan active – NC	The contact is opened when the fans are running.

## 71. Indoor temperature sensor

Select the sensor which the system must use for the indoor temperature:

- Select the sensor on the unit if no room sensor has been implemented.
- Select the room sensor if this has been implemented.
- Select the average between the unit sensor and the room sensor.

It is possible to limit the room temperature that can be set by the user. Set a minimum and a maximum room temperature.

## 4.7 Maintenance

The menu **Maintenance** contains information on the use of the unit and offers a number of functions which are necessary for remedying errors.

### Status

The status screen displays general information about the installation and specific information per group and per unit connected.

### Current errors

Gives an overview of current errors. The error messages can also be deleted here.

### Error history

Gives an overview of the errors which have occurred.

### Capacity test

Use this function to test the capacity of the unit and your heating installation.

The unit will run for 120 minutes at the highest fan speed and with the highest heating capacity. You can check the discharge temperature and the heating capacity per metre of unit length. The discharge temperature is limited to 50°C.

#### **For units with water heating:**

if the heating capacity is too low, check the supply and return water temperatures and the water flow.

### Valve check

Use this function to check the operation of the water valve:

1. Set the opening percentage of the valve to 0%;
2. Press start. The fans will start rotating at the highest speed;
3. Check whether the discharged air is cold;



#### **Note:**

It may take some time before the valve reaches the adjusted opening percentage.

4. Repeat steps 1 and 2 for the percentages 50% and 100% as well. In doing so, check whether the discharged air gets warmer per step.

### Check door contact switch

With this function, you check the operation of a door contact switch connected to the unit. For this purpose, you have to open and close the door, so that the control panel can detect the switch.

### Installation

This installation guide leads you through the most frequently required settings.

The installation guide is started up automatically during the first start-up of the unit or after the resetting of the factory configuration.

### Unit code

For entering the unit code after replacement of the control circuit board in a unit.

### Default settings

Restores the default factory settings of the setup menu. The settings entered in the configuration menu are retained.

### Factory configuration

Restores the standard factory configuration. All settings are then lost.



**Note:**

The installation guide will be restarted.

### Reset system

The control panel searches for connection with the attached units again. Use this function when remedying errors and during connection or disconnection of units.

## 4.8 USB

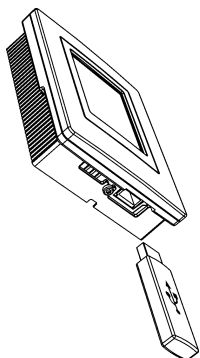

The control panel is equipped with a USB port to which only a USB flash drive can be connected. This is used for:

- updating the software
- importing and exporting settings
- exporting usage data

This menu is automatically activated when a USB flash drive is connected. The menu is closed again when the USB flash drive is removed.



### **Caution:**

Do not remove the USB flash drive during the updating or during the importing or exporting of data. This can take several minutes.



### **Warning:**

**Connection of other electronic devices to the USB port can cause serious damage to the control panel or to other electronic components.**

### Software update

Biddle is working continuously on improving its products and recommends that you update the software of the control panel when updates become available. Consult [www.biddle.info/software](http://www.biddle.info/software) to see if updates are available.

- The installed version of the software can be read out from [Maintenance > Status](#).
- Download the latest version of the software via Biddle's website.

See also: [7.11 Updating the software](#)

### Upload logo

It is possible to use your own logo or image as background for the display.

Requirements for the image:

- Windows bitmap;
- Filename: logo.bmp;
- Dimensions: maximum 240 x 320 pixels;
- Colour depth: 8-bit grayscale or 24-bit colour.



### **Note:**

Uploading your own logo replaces the standard Biddle logo.

### Export/import settings

For copying settings between control panels.

See also: 7.10 [Copying the settings](#)

### Exporting system info

Export the file 'system\_info' for an overview of all connection control circuit boards and control panels with corresponding software versions.

### Export log...

The Export log functions write data concerning the operation of the unit to the USB flash drive. These files can then be analysed on a computer.

The files contain the following data:

- log\_func: Data concerning the operation of the unit.
- log\_error: Error report history.
- log\_user: User settings history.
- log\_stat: *not in use*.
- system\_info: Overview of connected control circuit boards and control panels.



**Note:**

The process of exporting can take several minutes.  
Repeat if 100% is not achieved.

# 5. . Errors



## **Danger:**

All work on the inside of the unit may only be carried out by personnel who are technically qualified to do so.



## **Warning:**

Before you begin: read the safety instructions.

## 5.1 Resolving simple problems

If you suspect an error, first try to resolve the problem, using the table below. You do not have to be an expert in order to do this.

If this fails to resolve the problem, there may be a fault; in that case, alert the installer.

Some problems can be resolved simply by resetting the system once. (see [5.2 Error messages on the control panel: Reset system](#))

PROBLEM	PROBABLE CAUSE	WHAT TO DO
The unit does not work.	The unit has not been switched on	Switch the unit on
	The unit has no power supply.	Check the mains supply: <ul style="list-style-type: none"> <li>• isolation switch,</li> </ul>
	The unit has been switched off by external control components	Check external control components, if present: <ul style="list-style-type: none"> <li>• door contact switch: is the door open?</li> </ul>
	The unit has been switched off by the thermal cut-out.	<ol style="list-style-type: none"> <li>1. Switch the unit off using the control panel.</li> <li>2. Allow the unit to cool down.</li> <li>3. Turn the unit on and check whether it is now working again.</li> </ol> Contact Biddle if this error occurs repeatedly.
The unit has been switched off but is nevertheless still operating.	<i>Only for electrically heated models:</i> the unit cools down automatically.	This is not an error. Normally, the unit will automatically shut down within 10 minutes.

PROBLEM	PROBABLE CAUSE	WHAT TO DO
The unit is switched off but the fans continue rotating slowly.	An extra connected controller is providing power to the fans, so that these start up immediately when the door opens.	This is not an error.
The unit is switched on but is not discharging any air.	The fans may be switched off if there is only a small difference in temperature between indoors and outdoors.	This is not an error. <b>For units with b-touch:</b> If this is considered a problem, the value of function <a href="#">42. Fan OFF temperature</a> can be set to zero.
The unit is not discharging much air. (There is a draught)	The inlet and/or discharge section is blocked.	Remove obstacles to the inlet and discharge section.
	The unit is set at too low a strength.	Switch the unit to a higher strength.
	<i>Only for models with a filter:</i> The filter is dirty.	Clean or replace the filter.
	<i>Only for models with heating:</i> The heat exchanger has become dirty.	Clean the heat exchanger.
The unit is not heating or not heating sufficiently.	The unit is set at too low a strength.	Switch the unit to a higher strength.
	<i>Only for water-heated models:</i> The central heating system is not working properly.	Check the central heating system. <ul style="list-style-type: none"> <li>• Check the connections.</li> <li>• Check the operation.</li> <li>• Check the capacity.</li> </ul>
<b>For units which have automatic regulation and b-touch control panel:</b>		
The control panel display is black.	The control unit has no power supply.	Check the mains supply: <ul style="list-style-type: none"> <li>• plug in the power socket,</li> <li>• isolation switch,</li> </ul>
The display is on, but does not react to touch.	<i>If the  symbol is shown on the display:</i> The display is locked.	Touch the screen for 5 seconds to unlock it.
The display flickers	The power supply is too low or not constant	Reduce the brightness of the display to a level at which flickering no longer occurs, via <a href="#">menu &gt; Preferences &gt; Display brightness</a> .
The unit blows out cold air (without error message).	The discharge temperature is dependent on the outdoor and indoor temperature	This is not an error. If this is considered a problem, the value of function <a href="#">6. Minimum air temperature</a> can be increased.

PROBLEM	PROBABLE CAUSE	WHAT TO DO
The unit discharges cold air and the airflow on the display is blue.	The heating has been switched off manually.	Turn the heating on via <a href="#">menu &gt; Heating</a> .
	The heating has been switched off because the outdoor temperature is too high.	This is not an error. If this is considered a problem, the value of function <a href="#">41. Heating OFF temperature</a> can be increased.
	The (set) room temperature has been reached. The unit is ventilating unheated.	This is not an error.
	The heating has been switched off by a signal to the unit's input.	This is not an error. If this is considered a problem, the function of the input can be changed via <a href="#">60. Function of inputs</a> .
The heating is disabled (the airflow on the display is blue) and the unit is nevertheless blowing out warm air.	The heating has been switched on by the additional frost protection.	This is not an error. If this is considered a problem, the function <a href="#">45. Extra frost protection</a> can be disabled.
The unit is discharging air harder than expected	If there is a big difference between the set temperature and the actual temperature, a unit may temporarily operate at a higher setting in order to attain the pre-set temperature faster.	This is not an error. If this is considered a problem, you can switch off function <a href="#">33. Boost function</a> or set it to a different temperature difference or a different increase in the fan setting.
The door is closed but the fans are still running.	This may be caused by the settings for a closed door situation.	Check the settings of function <a href="#">25. Auto: Door response</a> .



## 5.2 Error messages on the control panel

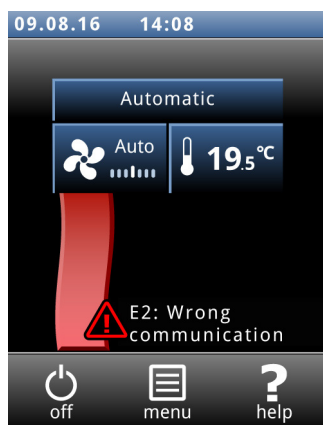

### 5.2.1 Reading out errors

#### Current errors

Current errors are displayed on the Home screen. If an error has remedied itself, a corresponding message will be displayed.

When the error message is touched, the screen displays an explanation, together with a list of the actions to be taken. The message will disappear from the Home screen only when the error has been remedied.

More than one error may occur at the same time. You can read out a list of current error codes via [menu > Maintenance > Current errors](#).

#### No-longer-current errors

If an error has remedied itself, a corresponding message will be displayed. Touch this message to display the error history and to read out the last five errors and the times of their occurrence. This list can also be read out via [menu > Maintenance > Error history](#).

This message will disappear when touched or when the unit is switched on again.

### 5.2.2 Deleting errors

Most error messages will disappear automatically when the problem is resolved. Certain errors have to be remedied, however, by deleting the error message via [menu > Maintenance > Current errors](#).

### 5.2.3 Reset system

Some errors can be remedied by resetting the control panel via [menu > Maintenance > Reset system](#): the panel will then search for connected units again.

In this process, all settings are retained.

### 5.3 Remediating errors that are accompanied by an error message

*For models with b-touch control panel: Try to remedy errors that are accompanied by an error message, making use of the error codes table. Technical expertise is required for this.*

CODE	PROBABLE CAUSE	WHAT TO DO
E1	<p>The control panel does not communicate with one or more connected units.</p> <p>This error may occur:</p> <ul style="list-style-type: none"> <li>• when a connected unit is removed or replaced,</li> <li>• due to a brief error in the power supply of a connected unit,</li> <li>• due to incorrect cabling,</li> <li>• due to a fault.</li> </ul>	<ol style="list-style-type: none"> <li>1. Check whether all connected units are provided with mains supply.</li> <li>2. Check whether the dummy plug on terminal X535 of the last connected unit is present.</li> <li>3. Check the control cables: <ul style="list-style-type: none"> <li>• are they correctly connected and free of breaks?</li> <li>• are they stretched out or rolled up in a bifilar coil?</li> <li>• are they shielded from magnetic fields?</li> </ul> </li> <li>4. Check the fuses.</li> <li>5. Check the wiring between the control panel and connections X530 and X535 and X60 in the unit.</li> <li>6. Reset the system if the error message does not automatically disappear.</li> </ol>
E2	There are units connected that have an invalid or unknown unit code, or an invalid combination of unit types.	Check and compare the unit types on the type plate. The units must have the same battery type and preferably the same capacity.
	The control panel software is outdated.	Check the version number of the software via <a href="#">menu &gt; Maintenance &gt; Status</a> .
	The control panel does have power but is not communicating with any unit.	<ol style="list-style-type: none"> <li>1. Check the control cables: <ul style="list-style-type: none"> <li>• are they properly connected and fully intact?</li> <li>• are they stretched out or rolled up in a bifilar coil?</li> <li>• are they shielded from magnetic fields?</li> </ul> </li> </ol>
E3	<p><i>For electrically heated models:</i></p> <p>The resistor on the printed circuit board for electric heating is not functioning properly.</p>	<ol style="list-style-type: none"> <li>1. Clear the error message.</li> <li>2. Check the connection of the R1.6K on the EVW printed circuit board. (see the wiring diagram)</li> </ol> <p>If this is in order: replace the resistor.</p>

CODE	PROBABLE CAUSE	WHAT TO DO
E4	<p><i>For electrically heated models:</i> A high-limit thermostat has switched the unit off: this is protection against overheating. This error may occur:</p> <ul style="list-style-type: none"> <li>• if the unit has been temporarily without power, e.g. due to a power failure;</li> <li>• if the filter is dirty and lets insufficient air through.</li> </ul> <p><b>In other cases, there may be a serious fault which may constitute a risk of harm to people.</b></p>	<ol style="list-style-type: none"> <li>1. Clear the error message.</li> <li>2. Check the fans. If one or more fans do not work, then check: <ul style="list-style-type: none"> <li>• the fan wiring;</li> <li>• the connection on the control circuit board (X344);</li> </ul> If these are in order, then replace the fan. </li> <li>3. Check the filter (if present) for contamination. Clean or replace it if necessary. Contact Biddle if this error occurs repeatedly.</li> </ol>
E5	<p><i>For electrically heated models:</i> The heating continues to operate because a relay is not working properly. <b>This may be a serious fault which may constitute a risk of harm to people.</b></p>	<ol style="list-style-type: none"> <li>1. Clear the error message.</li> <li>2. Switch the mains supply to the unit Off and On.</li> <li>3. Let the unit operate for some time with the heating disabled and check whether the discharged air stays cold.</li> </ol> <p>There is a dangerous fault if:</p> <ul style="list-style-type: none"> <li>• heating continues nevertheless;</li> <li>• this error message recurs after half an hour;</li> <li>• this error occurs repeatedly.</li> </ul> <p>In such cases, proceed as follows:</p> <ul style="list-style-type: none"> <li>• disconnect the unit from the power supply immediately;</li> <li>• contact Biddle.</li> </ul>
E6	<p><i>For water-heated models:</i> Risk of freezing because discharge temperature is too low. Frost protection has been activated. <b>Freezing may cause damage to the heat exchanger.</b></p>	<ol style="list-style-type: none"> <li>1. Clear the error message.</li> <li>2. Ensure that the temperature in the room rises above 8 °C.</li> <li>3. Follow the instructions for error code F3 You can prevent this error by setting the unit to switch on the central heating system when there is a risk of freezing (Function <a href="#">61. Function of outputs on Heating on</a>).</li> </ol>
E7	Fan error.	<ol style="list-style-type: none"> <li>1. Clear the error message</li> <li>2. Check the fans. If one or more fans do not work, then check: <ul style="list-style-type: none"> <li>• the fan wiring;</li> <li>• the connections on the control circuit board (X344);</li> <li>• the transformer fuse;</li> <li>• the transformer itself.</li> </ul> If these are in order, then replace the fan. </li> </ol>

CODE	PROBABLE CAUSE	WHAT TO DO
F2	<p><i>For water-heated models:</i> There is too much heating. This error may occur if the control valve does not work correctly.</p>	<ol style="list-style-type: none"> <li>1. Switch the unit OFF using the control panel, wait for one minute, and switch it ON again.</li> <li>2. Check that the connections of the supply and return pipes have not been interchanged.</li> <li>3. Check the wiring and connectors of the valve drive (X377) and the discharge temperature sensor (X350).</li> <li>4. Remove the drive from the valve and check the interior for mechanical operation and defects.</li> </ol>
F3	<p><i>For water-heated models:</i> The central heating system switches on later than the unit.</p>	<p>You can:</p> <ul style="list-style-type: none"> <li>• switch on the central heating system earlier;</li> <li>• set the unit to turn on the central heating: Set function <a href="#">61. Function of outputs</a> to <a href="#">Heating on</a> and connect the relevant output to the central heating system.</li> <li>• turn off this error message: Set function <a href="#">21. User interface options</a> &gt; <a href="#">Error display</a> to <a href="#">Disable</a>.</li> </ul>
	<p><i>For water-heated models:</i> There is too little heating. This error may occur:</p> <ul style="list-style-type: none"> <li>• if not enough hot water is supplied;</li> <li>• if the control valve does not work correctly.</li> </ul>	<ol style="list-style-type: none"> <li>1. Check the central heating system: <ul style="list-style-type: none"> <li>• is it turned on?</li> <li>• is it able to supply enough hot water?</li> </ul> </li> <li>2. Check whether the battery only becomes partially warm: if so, it needs venting.</li> <li>3. Check the wiring and connectors of the valve drive (X370) and the inlet temperature sensor (X360).</li> <li>4. Remove the drive from the valve and check the interior for mechanical operation and defects.</li> </ol>
	<p><i>For electrically heated models:</i> There is too little heating because one or more heating elements does/do not work.</p>	<ol style="list-style-type: none"> <li>1. Check the fuses of the mains supply.</li> <li>2. Check the wiring and connections of the heating elements, using the wiring diagram as a reference</li> </ol> <p>If they are OK, a relay is faulty: Contact Biddle.</p>
	<p><i>For all models:</i> If the fans do not rotate:</p>	<ol style="list-style-type: none"> <li>1. Check whether the fans are rotating. If one or more fans do not work, check: <ul style="list-style-type: none"> <li>• the wiring of the fans;</li> <li>• the connections on the printed circuit board (connectors X60);</li> <li>• the transformer fuse;</li> <li>• the transformer itself.</li> </ul> </li> </ol>
F5	<p>The temperature sensor in the unit's discharge section does not work.</p>	<ol style="list-style-type: none"> <li>1. Check the sensor's wiring and connection (connector X350).</li> <li>2. Replace the sensor.</li> </ol>

CODE	PROBABLE CAUSE	WHAT TO DO
F6	The temperature sensor in the unit's inlet section does not work.	<ol style="list-style-type: none"> <li>1. Check the sensor's wiring and connection (connector X360).</li> <li>2. Replace the sensor.</li> </ol>
F7	The outdoor temperature sensor is not working. On the home screen there is also a symbol indicating outdoor temperature sensor absent.	<p>If the wired outdoor temperature sensor comprises part of the system: The outdoor temperature is now based on a monthly average for your country.</p> <ol style="list-style-type: none"> <li>1. Check the wiring and connection of the outdoor temperature sensor (connector X540).</li> <li>2. Possibly, replace the sensor.</li> <li>3. Via the installation guide, you can possibly opt not to use the outdoor temperature sensor.</li> </ol> <p>If the wired outdoor temperature sensor does not comprise part of the system:</p> <ol style="list-style-type: none"> <li>1. Clear the error message.</li> <li>2. The symbol indicating outdoor temperature sensor absent remains on the home screen if the outdoor temperature is not measured by the IR sensor either, but is based on a temperature table.</li> </ol>
F12	<p>If function 71. <b>Indoor temperature sensor</b> is set to Room sensor The room sensor does not work. The indoor temperature is now based on the temperature sensor in the inlet section of the unit.</p>	<ol style="list-style-type: none"> <li>1. Check the wiring and connection of the sensor (connector X354).</li> <li>2. Replace the sensor.</li> </ol>
F16	<p><i>For models with Daikin direct expansion system and electrical heating (type DKE):</i> Heating medium sensor does not work. The electrical heating is not switched on in the defrost mode.</p>	<ol style="list-style-type: none"> <li>1. Check the wiring and the connection of the medium sensor (connector X354)</li> <li>2. Possibly, replace the sensor.</li> <li>3. Possibly, activate the electrical heating via function &gt; Hybrid heating</li> </ol>

## 5.4 Remediating errors that are not accompanied by an error message

If you suspect an error but no error message is displayed:

1. Referring to the preceding sections, check whether you can easily resolve the problem.
2. Try to resolve the problem using the table below. Technical expertise is required for this.

PROBLEM	PROBABLE CAUSE	WHAT TO DO
The control panel works normally but the unit does not respond.	The unit is being operated by a signal from an external control.	1. Check functions <a href="#">60. Function of inputs</a> and <a href="#">Release delay input 1</a> in the menu <a href="#">Configuration</a> .
	The fans may be switched off if there is only a small difference in temperature between indoors and outdoors.	This is not an error. If this is considered a problem, the value of the function can become <a href="#">42. Fan OFF temperature</a> .
	The power supply to the fans is cut.	1. Check the transformer fuse. 2. Check the wiring between the transformer and the fans. 3. Replace the transformer.
The display flickers	The length of the control cable between the control panel and the first unit is too great	Remove excessive length of cable
The unit is not functioning, the display is black and does not react to touch.	The unit is not receiving power.	Check the mains supply: <ul style="list-style-type: none"> <li>• isolation switch,</li> <li>• unit has power.</li> <li>• connections and wiring of the power supply.</li> </ul>
	The connection between the control panel and the control circuit board is not good.	1. Check the control cable. 2. Check the wiring between the connector plate and the control circuit board (connectors X530 and X60).
	The control circuit board is not working; the LEDs on the control circuit board are not lit.	1. Check fuse FI41. 2. Check the mains power cable (connector X01). 3. Replace the control circuit board.
	The control panel is faulty.	Check the control panel by connecting it to another unit with another cable. Replace the control panel if it is not working.
One fan does not work.	The fan is not receiving a power supply or is faulty.	1. Check the wiring of the fan. 2. Check the transformer fuse. 3. Replace the fan.
The fans do not work at a particular speed level.	The connection to the relevant branch is not good.	1. Check the transformer connections. 2. Check connector X60.
	The extra controller is not connected properly	Check that the bridge has been removed from between positions 5 and 6 of the connector X60.
The earth leakage circuit breaker switches the unit off.	The earth leakage circuit breaker present is not compliant.	Ensure that an earth leakage circuit breaker <b>type B</b> is present, preferably 300 mA.

# 6 . . Maintenance

## 6.1 Introduction

This chapter comprises those maintenance activities that the user himself can perform. Maintenance activities and repairs that must be performed by an installer are described in chapter [7 Servicing](#).

## 6.2 Cleaning the unit



**Danger:**  
**Units with electric heating may not be cleaned with water.**

You can clean the inside and the outside of the unit with water and household cleaning products. Do not use any solvents.

The fans too can be cleaned with water. There are holes in the unit for the drainage of any water present.



**Warning:**  
**No water under high pressure may be sprayed onto the fans or the terminal boxes.**

Carefully remove dust in the heating element with a vacuum cleaner.

## 6.3 Scheduled maintenance

### 6.3.1 Monthly maintenance

#### With all units:

- Check the heating elements and the fans for dust and other dirt; if necessary, clean.
- Check that all fans work.
- Check that the air curtain works in all of the control unit's operating modes.
- Check the discharge section for pollution/dirt and/or blockage; if necessary, clean.

**For units with water heating:**

- Check for water leakage; if this should be the case, then switch off the unit so that it is electrically dead and repair the leakage.
- Check whether the water piping system contains air; if necessary, vent the air out of the system.

**See also:**

6.2 "Cleaning the unit" on page 87

1 "Switching ON and checking operation" on page 1

**6.3.2 Annual maintenance****With all units:**

- Carry out all monthly checks.
- Check the cabling between the terminal boxes in the units and the control unit.
- Inspect the casing, the suspension or mounting structure, and the securing of each unit.
- Check whether the fans are firmly attached and are not running out of true; if necessary, fasten them again.

**For electrically heated units:**

- Check the wiring between the control unit and the heating section.
- Check the mains power cables and the connections in the heating section.
- Check the relay in the heating section.



# 7 . . Servicing



**Warning:**

Servicing activities may only be carried out by personnel who are technically qualified to do so.



**Warning:**

Before you begin: read the safety instructions.

**See also:**

1.5 "Safety instructions" on page 15

## 7.1 Removing the fans

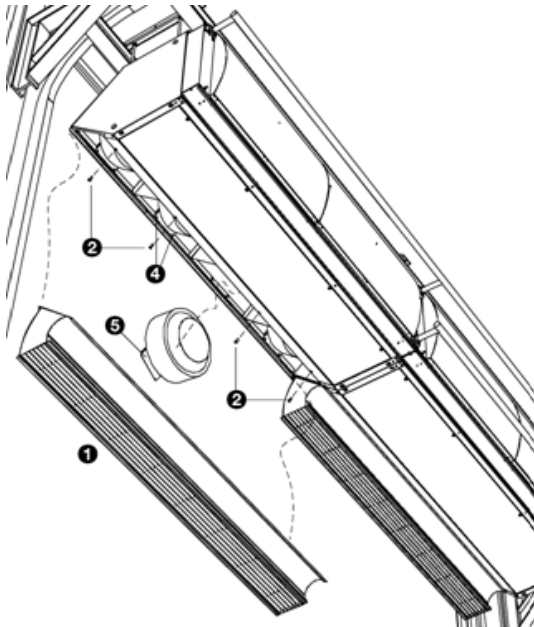

**With horizontal installation position type 0 and with vertical installation position type I:**

1. Remove the discharge section:
  - Loosen the bolts ②.
  - Unhook the discharge section ①.
2. Disconnect the wiring:
  - Remove the inspection panel ③.
  - Open the terminal box.
  - Disconnect the wiring of the relevant fan.
3. Remove the fan:
  - Loosen the bolts ④.
  - Take out the fan along with bracket ⑤.

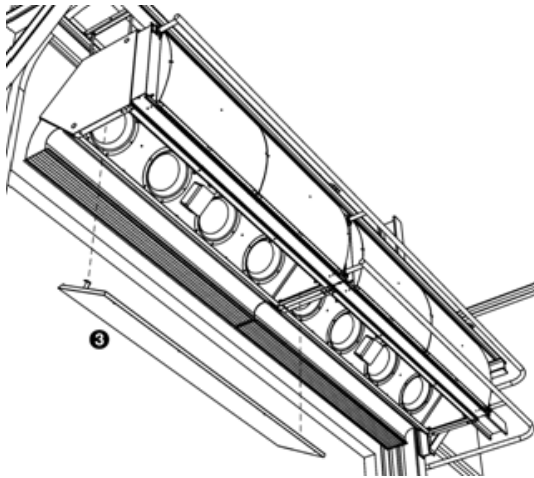

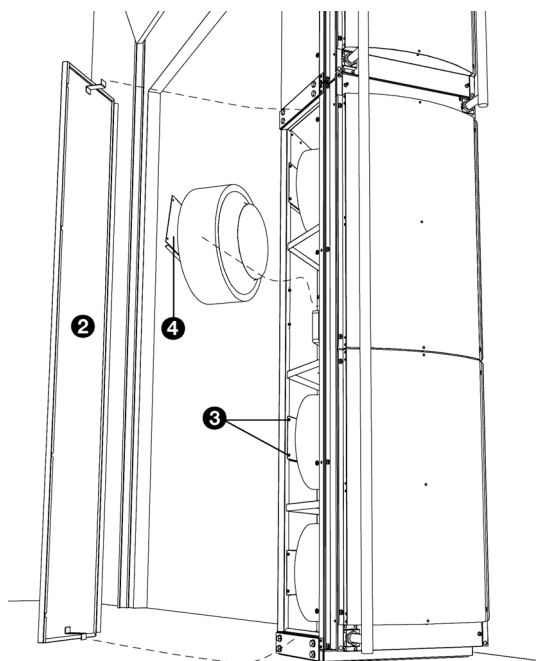
**With vertical installation position type 2:****1. Disconnect the wiring:**

- Remove inspection panel ②.
- Open the terminal box.
- Disconnect the wiring of the relevant fan.

**2. Remove the fan:**

- Loosen the bolts ③.
- Take out the fan along with bracket ④.

**See also:**

2.6.2 "Connecting the unit (types A and H)" on page 31

## 7.2 Accessing the heating element

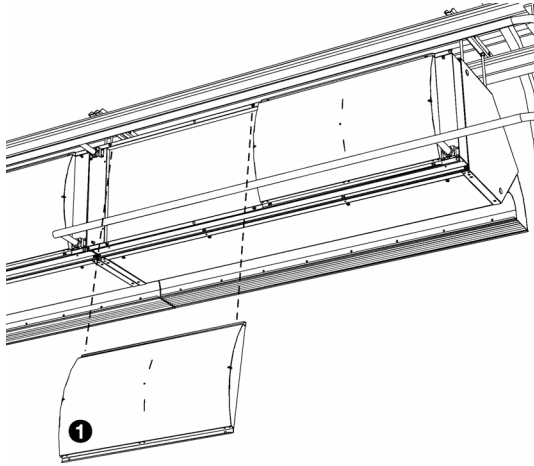

**For units with water heating:**

1. Remove inlet grille ❶.

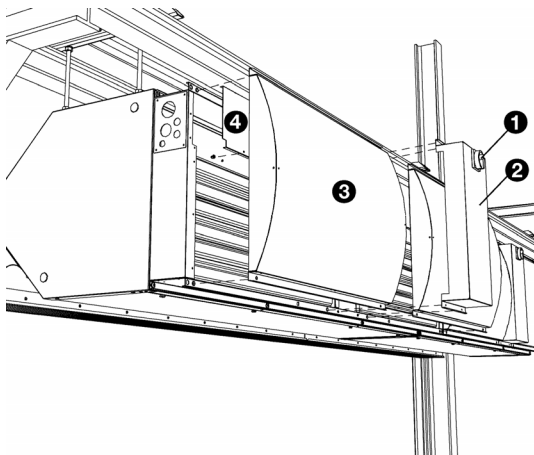
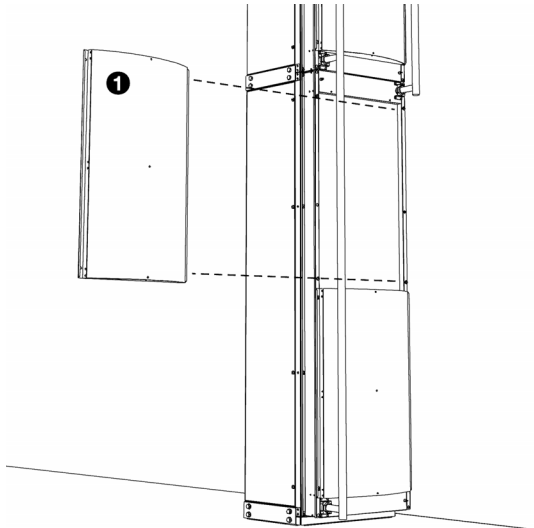

**For electrically heated units:**

1. Set isolation switch ❶ on the unit to position 0.
2. Remove the cover ❷.
3. Remove the inlet grille ❸.
4. Remove the cover plate of the cable space ❹.

## 7.3 Electronics module

### Only for units which have automatic *CHIPS* control

The unit contains one electronics module. Depending on the version, one can find on this such things as:

- the transformer;
- the control circuit board;
- the connector plate;
- the fuses.
- the filters
- the reactor

## 7.4 Removing the control circuit board

1. Switch the unit off using the control panel.



**Warning:**  
**Shut off the mains supply.**

**The unit is fitted with 2 mains power cables. Ensure that the power supply to the control circuit board is also shut off.**

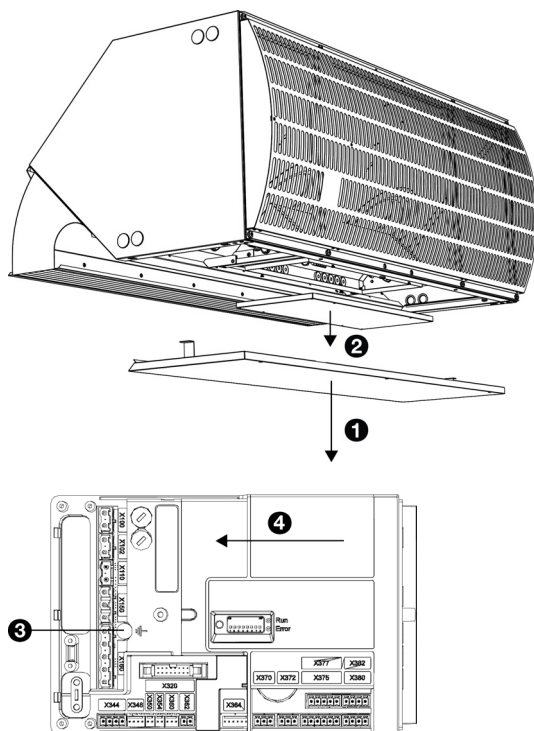

2. Remove the inspection panel ❶.
3. Open the electronic housing ❷.
4. Disconnect all connectors attached to the unit and earth connections from the control circuit board.
5. Remove the screw ❸.
6. Slide the control circuit board ❹ loose and lift it out of the unit.

## 7.5 Connecting the control circuit board



**Warning:**  
Make sure that the mains supply is switched off

1. Slide the control circuit board into its place and screw it in firmly.
2. Connect all connectors and earth connections to the control circuit board again.
3. Switch the unit on and check the operation.



**Note:**  
With a new control circuit board, an EI error may occur because the old control circuit board can no longer be found. Resolve this by reconfiguring the system via [menu > Maintenance > Reset system](#)



**Note:**  
If you are asked to designate a new master unit, then preferably select a unit whose control circuit board has not been replaced. In that event, the settings will be preserved.

## 7.6 Fuses

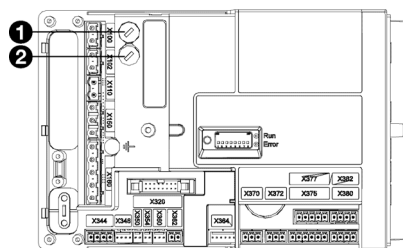

The control circuit board of the unit is fitted with the following fuses:

- fuse F140 ❶ of the transformer.
- fuse F141 ❷ of the control circuit board.

The values are indicated on the fuses.

## 7.7 LEDs

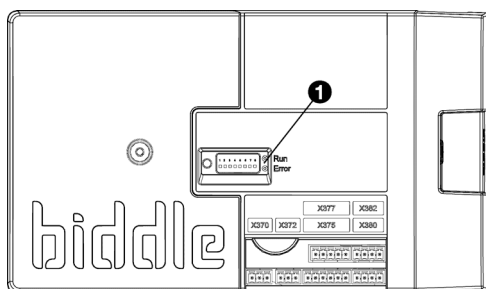

The LED lights ❶ on the control circuit board indicate the following:

- *continuous green*: The control circuit board is receiving a power supply.
- *flashing green*: The unit code can be entered.
- *continuous red*: There is a local error.



### Note:

This does not necessarily always result in an error message on the control panel.

## 7.8 Setting the unit code

The unit code must be set after replacement of the control circuit board in the unit. The unit code depends on the unit type and is indicated on the type plate.

To set the unit code, there are two methods:

- directly via the control panel if a single unit is connected;
- via the control circuit board and the control panel if more than one unit is connected.



### Warning:

Entering an incorrect code will result in poor performance of the unit.

### 7.8.1 Setting the unit code via the control panel



### Caution:

Setting the unit code using this method will only work if just a single unit is connected to the control panel. If necessary, connect the control panel separately to the unit in question.

1. Select [menu > Maintenance > Unit code](#).
2. Enter the unit code via the control panel and press [ok](#).

The control panel will now search for the unit again.

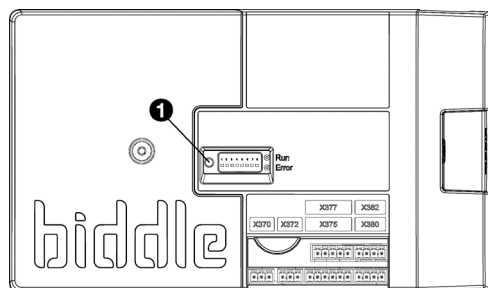

### 7.8.2 Setting the unit code via the control circuit board and the control panel

1. Connect the mains supply (insert the plug into the socket or move the isolation switch to ON).



**Warning:**  
Do NOT touch any live parts.

2. Press down the microswitch **1** on the control circuit board .

The LED next to the microswitch will start flashing.

The control panel displays eight numbers: these comprise the unit code.

3. Enter the unit code via the control panel and press **ok**.
4. Press down microswitch .

The LED next to the microswitch will stop flashing.

The unit code is now set.

5. Reset the control panel.

## 7.9 Resetting the PIN code

The PIN code of the control panel can be reset using a USB flash drive:

1. Connect a USB flash drive to the control panel.

The USB menu is activated

2. Press  for 10 seconds.

The PIN code is reset and a new PIN code has to be entered.

3. Exit the USB menu by removing the USB flash drive.

## 7.10 Copying the settings

The settings of the unit can be copied to another unit.

### 7.10.1 What you need

Before copying the setting, check that you have the following:

- An empty USB flash drive. The USB flash drive must be formatted for FAT or DOS. Do not use a USB hard disk for the software update.



### 7.10.2 Step 1: Copying the settings of the correctly-set unit

1. Check whether the settings to be copied on the original b-touch control panel are all correctly set.
2. Connect the USB flash drive to the USB port of the b-touch control panel.



**Note:**

If the USB flash drive is not detected, disconnect it and then connect it again.

The control panel detects the USB flash drive and displays the USB menu

3. Select **Export Settings**

The progress percentage is displayed.

4. When this has been completed, disconnect the USB flash drive from the control panel.

### 7.10.3 Step 2: Copying the settings to another unit

1. Connect the USB flash drive (with the settings that are to be copied) to the USB port on the other control panel.
2. Keep the function **Import settings** pressed down until the progress of the process is displayed.

The settings are now being imported.



**Note:**

Below the progress percentage, the name of the file to be imported is visible: 'settings\_export.txt'

3. When this has been completed, disconnect the USB flash drive from the control panel.
4. Repeat steps 1 to 3 for each control panel to which you wish to apply the same settings.

## 7.11 Updating the software

Biddle is working continuously on improving its products and recommends that you update the software of the control panel and of the control circuit board when updates become available. Consult Biddle's website for availability.

### 7.11.1 What you need.

Before updating the software of the control panel, check that you have the following:

- An empty USB flash drive. The USB flash drive must be formatted for FAT or DOS. Do not use a USB hard disk for the software update.
- A PC with Internet access.

### 7.11.2 Step 1: Check the current software version

Before you update the software of the control panel or of the control circuit board, you must check the existing software version. If the software version is the same as that of the most recent update file on Biddle's website, you do not need to update the software.

1. Press [menu](#) in the Home screen.
2. Select [Maintenance](#). The version of the current software is displayed in the status overview.

### 7.11.3 Step 2: Download the most recent software

1. Connect the USB flash drive to a USB port on your PC.
2. On your PC, go to Biddle's website and look under Downloads.
3. Look for your product and the available software for your unit.
4. If the software version is more recent than the version on your control panel, click on the software update.
5. Accept the licence agreement and save the file to the main directory of the USB flash drive.
6. Disconnect the USB flash drive from the PC.

### 7.11.4 Step 3: Updating the software



#### **Warning:**

Do not switch off the unit or disconnect the USB flash drive during the software update. Do not disconnect the USB flash drive from the control panel even if there is a power failure during the update. The update will resume as soon as the power returns. If an error occurs during the update, start the procedure again. If the error continues to occur, contact Biddle.

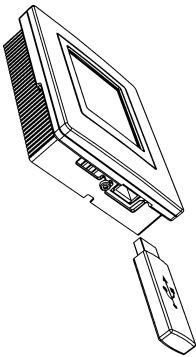

1. Connect the USB flash drive (with the software update) to the USB port on the control panel.



#### **Note:**

If the USB flash drive is not detected, disconnect it and then connect it again.

The control panel detects the USB flash drive and displays the USB menu

2. Select [Software update](#) to update the software.
3. When this has been completed, disconnect the USB flash drive from the control panel.

## 7.12 Composition of the Biddle control cable

The control cable for the control system is constructed as follows:

- The plugs are modular connectors of the type 6P4C.
- Connectors are untwisted, i.e. at both ends of the cable, cores are connected to the same electrode.

#### **Colour coding of Biddle cables**

	ELECTRODE	COLOUR
	1	(not used)
	2	black
	3	red
	4	green
	5	yellow
	6	(not used)

# 8. . Dismantling

The dismantling of the installation and the handling of the coolant, oil and other components must be done by a qualified fitter in conformity with the relevant local and national legislation and regulations.

Pursuant to EU legislation, used electrical and electronic appliances must be collected for recycling. By ensuring that this product is disposed of in the correct manner, you are helping to prevent potential negative consequences for the environment and public health. For more information about this, please contact your supplier or the relevant government authority.

# 9 . . Addresses

If you have any comments or queries relating to this product, please do not hesitate to contact your Biddle branch.

**Biddle bv**

P.O. Box 15  
9288 ZG Kootstertille  
The Netherlands

**T** +31 (0)512 33 55 55

**E** [info@biddle.nl](mailto:info@biddle.nl)

**I** [www.biddle.nl](http://www.biddle.nl)

**Biddle nv**

Battelsesteenweg 455 B  
2800 Malines  
Belgium

**T** +32 (0)15 28 76 76

**E** [biddle@biddle.be](mailto:biddle@biddle.be)

**I** [www.biddle.be](http://www.biddle.be)

**Biddle Air Systems Ltd.**

St. Mary's Road, Nuneaton  
Warwickshire CV11 5AU  
United Kingdom

**T** +44 (0)24 7638 4233

**E** [sales@biddle-air.co.uk](mailto:sales@biddle-air.co.uk)

**I** [www.biddle-air.com](http://www.biddle-air.com)

**Biddle GmbH**

Emil-Hoffmann-Straße 55-59  
50996 Cologne  
Germany

**T** +49 (0)2236 9690 0

**E** [info@biddle.de](mailto:info@biddle.de)

**I** [www.biddle.de](http://www.biddle.de)

**Biddle France**

21 Allée des Vendanges  
77183 Croissy Beaubourg  
France

**T** +33 (0)1 64 11 15 55

**E** [contact@biddle.fr](mailto:contact@biddle.fr)

**I** [www.biddle.fr](http://www.biddle.fr)

**N° Vert 0 800 24 33 53**

**N° Vert 0 800 BI DD LE**

# . . . Keywords

## A

accessories . . . . .	15
addresses . . . . .	101
alarm signal . . . . .	48
An. . . . .	6
application limits . . . . .	11

## B

BACnet . . . . .	50
base plate . . . . .	24
battery type . . . . .	9
baud rate . . . . .	50

## C

capacity . . . . .	9
CE declaration . . . . .	13, 14
central heating system . . . . .	25
CHIPS control . . . . .	7
cleaning . . . . .	87
communication parameters . . . . .	50
connecting power supply . . . . .	29
connecting the piping . . . . .	25
control . . . . .	9
control cable . . . . .	99
control valve . . . . .	27

## D

delivery inspection . . . . .	17
designations . . . . .	4
determine location . . . . .	19, 23
disable . . . . .	57
discharge temperature, maximum . . . . .	11
dismantling . . . . .	100
door contact switch . . . . .	48

## E

electronics module . . . . .	93
errors . . . . .	61, 78
delete . . . . .	81
reading out . . . . .	81

## F

finishing . . . . .	52
frost protection . . . . .	28
fuses . . . . .	94

## I

installation . . . . .	17
b-control . . . . .	35
b-touch . . . . .	40
external controls . . . . .	44
installation position . . . . .	9
installing control unit	
b-control . . . . .	35
b-touch . . . . .	40

## L

length . . . . .	9
------------------	---

## M

mains supply . . . . .	29
maintenance . . . . .	87
Modbus . . . . .	50
modifications . . . . .	14

## O

operating package . . . . .	14
operating pressure, maximum . . . . .	11
operation . . . . .	6
b-control . . . . .	57
b-touch . . . . .	58
outdoor temperature sensor . . . . .	45

## P

parity . . . . .	50
PIN code . . . . .	96
positioning . . . . .	24
power . . . . .	11
power supply voltage . . . . .	11
problems . . . . .	78
product series . . . . .	9

## R

- removing fan . . . . . 90
- room sensor . . . . . 47

## S

- safety instructions
  - installation . . . . . 16, 17
  - maintenance . . . . . 16, 78
  - servicing . . . . . 16, 89
  - usage . . . . . 15
- servicing . . . . . 89
- side shield . . . . . 22
- stop bits . . . . . 50
- strength . . . . . 57, 61
- suspension . . . . . 18, 20
- switching ON . . . . . 53, 57
- symbols . . . . . 4, 5

## T

- type code . . . . . 8
- type designation . . . . . 8
- type plate . . . . . 11
- typecode . . . . . 8

## U

- unit code . . . . . 95
- updating software . . . . . 98
- USB . . . . . 76

## V

- vertical installation . . . . . 22

## W

- water flow-path, maximum . . . . . 12
- water-side control . . . . . 26
- wiring . . . . . 50
- wiring diagram . . . . . 5
- working method . . . . . 17

## Copyright and Trademarks

All information and drawings contained in this manual are the property of Biddle and may not be used (other than for the purpose of operating the unit), photocopied, reproduced, translated and/or communicated to third parties without prior written permission from Biddle.

The name Biddle is a registered trademark of Biddle bv.

## Warranty and liability

For the warranty and liability provisions and terms, please refer to the terms & conditions of sale and supply.

At all times, Biddle shall not be held liable for consequential damages.

## Liability as regards the manual

Although great care has been taken to ensure the correct and, where necessary, complete description of the relevant components, Biddle shall not be held liable for damages as a consequence of errors and/or imperfections in this manual.

Biddle reserves the right to alter the specifications as mentioned in this manual.

Should you nevertheless discover any errors or ambiguities in the manual, we shall be glad to learn that from you. It helps us to improve the documentation still further.

## For more information

If you have any comments or queries relating to this product, please do not hesitate to contact Biddle. You will find the contact information for your Biddle branch in chapter [9 Addresses](#).

**Biddle bv**  
P.O. Box 15  
9288 ZG Kootstertille  
The Netherlands  
  
**T** +31 (0)512 33 55 55  
**E** [info@biddle.nl](mailto:info@biddle.nl)  
**I** [www.biddle.nl](http://www.biddle.nl)

Name and telephone number of installer: